

GAZELLE[®]

G9320 Underground Utility Locator User Manual



CONTENT

1.	General description	3
1.1	Function feature	4
1.2	Optional extension function module	4
1.3	Optional accessories	5
1.4	Tech. specification	5
1.5	Device composition	6
1.6	Receiver information and menu setting	9
2.	Common signal output method	11
2.1	Direct connection mode	12
2.2	Clamp coupling mode	15
2.3	Radiation mode	17
3.	Signal transmitting method for cable detection	19
3.1	Signal transmitting method for dead cables	19
3.2	Signal transmitting method for live cables	23
4.	Active detection	26
4.1	Pipe route tracing (path tracing)	26
4.2	Depth measurement	33
5.	Passive detection	38
5.1	Route tracing (path tracing)	38
5.2	Depth measurement	39
6.	Cable identification (optional function)	40
6.1	Flexible clamp smart identification	40
6.2	Flexible clamp current measurement	45
6.3	Sensor identification	45
7.	Pipeline grounded fault pinpointing (optional function)	47
8.	Cable fault pinpointing for low impedance and break fault	53
8.1	Phase to phase short circuit fault pinpointing	53
8.2	Phase to armor fault pinpointing	55
8.3	Break fault pinpointing	55
8.4	No armor cable phase to earth fault pinpointing	57
9.	Maintenance and warranty	58

1. GENERAL DESCRIPTION

PD-6900 intelligent cable and pipe locator is a high performance underground cable and pipe locating and identification system. It consists a transmitter and a receiver, can be used for route tracing, pipe exploration and depth measurement of the underground cables and metallic pipes. It can also be used to identify target cable from a bunch of cables, to do non-metallic pipe route tracing and depth measurement, locate the pipe insulation damage and part type cable fault.

MAIN UNIT

OPTIONAL ACCESSORIES



Depth measurement
auxiliary sensor



Transmitter clamp



Flexible identification clamp



Stethoscope



1kV output booster



A frame

Fig.1-1-1 Device appearance

1.1 FUNCTION FEATURE:

- Multiple function integrated: Route tracing + cable identification +A frame fault location + Sonde mode
- Color compass display: underground pipelines are in plain view.
- Ultra-high sensitivity: 0.5Hz ultra-narrow bandwidth receiving make device highly anti-interference.
- Correct and error tracking indication: eliminate interference from adjacent pipelines.
- Enhanced depth measurement: real-time accurate depth measurement.
- Depth measurement auxiliary sensor: signal distortion warning.
- Multi- passive detection frequency bands: AFB all frequency band passive detection, power frequency ,radiation passive frequency measurement.
- AFB all frequency passive detection: no need to select the frequency band, automatic analysis of the full frequency signal, intelligent and convenient.
- High performance transmitting clamp: running cable coupling transmitting signal.
- Flexible clamp for cable unique identification: convenient and highly reliable, and support current measurement.
- Step voltage detection: ground insulation damage fault location.
- Sonde mode: matching with sonde to realize the non-metallic pipe route tracing and depth measurement.
- High power digital amplifier transmission, automatic impedance matching, automatic protection.
- Transmitter supports variety signal output modes: direct output, clamp coupling mode, and radiation induction mode.
- Transmit/receive all digital processing, stable and reliable.
- Built-in large capacity lithium battery group, automatic power off when under voltage or long time without operation.
- IP65 high level protection.
- USB-C Gallium nitride fast charger.

1.2 OPTIONAL EXTENSION FUNCTION MODULE

- Built-in L1/L5 high-precision GNSS positioning module: path information recording and distance measurement.
- Built-in storage module and Bluetooth communication : Stores and exports recorded data to the upper computer.

1.3 OPTIONAL ACCESSORIES

- Depth measurement auxiliary sensor: interference indication during depth measurement.
- Transmitting clamp: coupling signals to running cables.
- Flexible clamp: cable unique identification.
- Stethoscope: cable identification for narrow occasions.
- Output booster and A frame: Used to locate portion cable faults and pipeline insulation breakages.
- Sonde: used for non-metallic pipe route tracing and depth measurement.
- External RTK GNSS centimeter-level positioning module: used for high-precision path information recording and distance measurement.

1.4 TECH. SPECIFICATION:

1.4.1 Transmitter

- Output mode: direct connection mode, clamp coupling mode, radiation mode, booster mode.
- Output frequency: 640Hz, 1280Hz, 8kHz, 33kHz, 82kHz, 197kHz.
- Output power: 15W Max, 10 levels adjustable.
- Impedance matching: full automatic.
- Over voltage and over current protection: full automatic.
- Human-machine interface: 320×240 dot matrix color LCD. Visible in sunlight.
- Power: Built-in Lithium battery group, nominal 7.4V, > 6AH
- Charger input: AC100-240V, 50/60Hz. USB-C port PD fast charge.
- Volume: 280×220×90mm.
- Weight: 2.3 kgs.
- IP 65
- Conditions of use: -25°C-60°C, <90%RH, <4500m

1.4.2 Receiver

- Receiving types: built-in coils, flexible clamp, stethoscope, booster.
- Detection mode: wide peak, narrow peak, valley value, historical curve, accurate positioning.
- Active frequency: 640Hz, 1280Hz, 8kHz, 33kHz, 82kHz, 197kHz.
- Passive frequency: AFB all frequency band passive detection, Power frequency and 2/5/9 times harmonics, 4.5~15k, 15~25k, 25~40k.
- Human-machine interface: 320×240 dot matrix color LCD, visible in sunlight.
- Power: Built-in lithium ion battery pack, nominal 7.4V, > 3Ah.

- Charger input: AC100-240V, 50/60Hz.
- Charger output: DC8.4V, 2A. USB-C port PD fast charge.
- Volume: 680×120×277mm.
- Quality: 2.0kg.
- IP65.
- Conditions of use: -25°C-60°C, <90%RH, <4500m.

1.5 DEVICE COMPOSITION:

1.5.1 Transmitter:

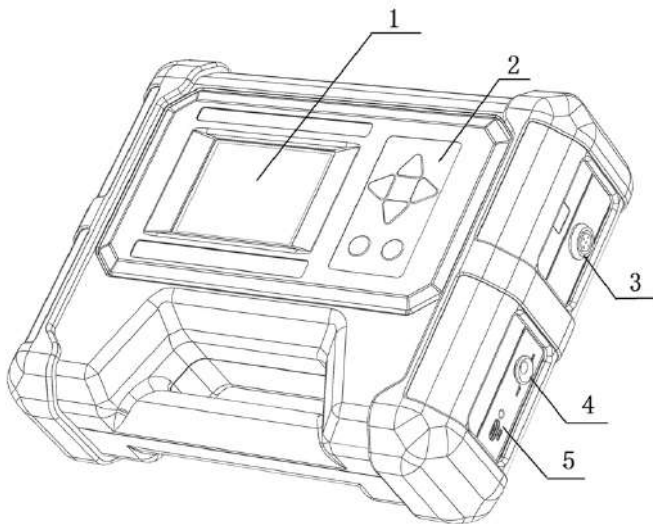

Fig.1-5-1 transmitter appearance

1. LCD display
2. Keyboard
3. External power socket
4. Accessories input socket
5. Charger socket

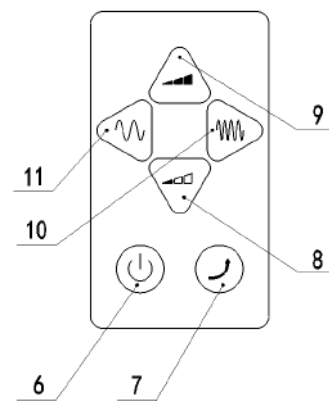

Fig.1.5-2 transmitter key buttons

6. Power on/off button
7. Re-output
8. Output power decrease button
9. Output power increase button
10. Frequency increase button
11. Frequency decrease button

1.5.2 Receiver:

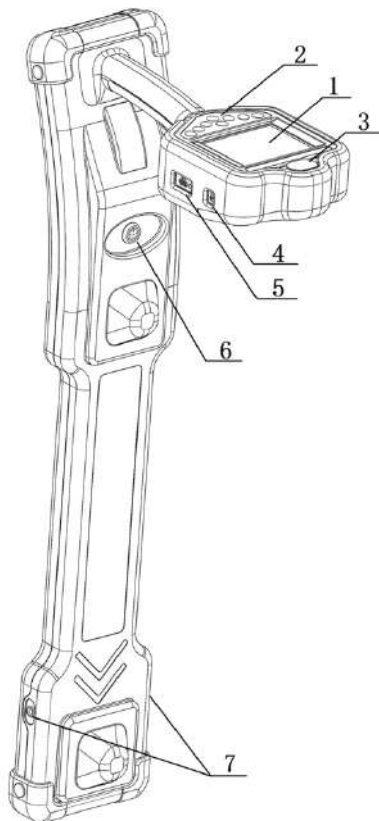

Fig.1-5-3 receiver appearance

1. LCD display
2. Key buttons
3. GPS socket
4. Earphone socket
5. Charge port
6. Accessories socket
7. Depth measurement auxiliary sensor socket

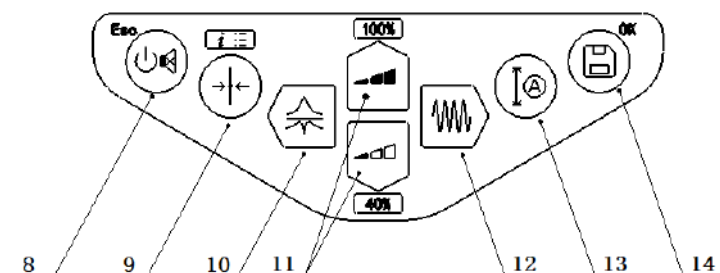















Fig.1-5-4 receiver buttons

8. Power on/off/mute (Set/Cancel ESC key in menu)
9. Calibration key (Menu cancel/long press: menu entry and exit key)
10. Mode key (left menu)
11. Gain increase and decrease key(menu up and down key)
12. Frequency key (menu right key)
13. Measure key
14. Storage key (menu enter key)



1.5.3 Standard accessories:

Item	Accessories name	Reference fig. and description	Qty
1	Transmitter direct connection output cable		1
2	Grounding rod		2
3	Earth extension cable	-	1
4	Gallium nitride fast charger		1
5	Dual USB-C charging cable		2

1.5.4 Optional accessories:

Item	Accessories name	Reference fig. and description	Qty
1	Receiver accessories connection cable	 blue 6-core plug cable	
2	Transmitter accessories connection cable	 red 5-core plug cable	
3	Depth measurement auxiliary sensor		
4	Transmitter clamp		
5	Receiver flexible clamp		
6	stethoscope		
7	Booster for fault location		
8	A frame for fault location		
9	Built-in GNSS antenna		
10	External RTK location module		
11	Sonde		

1.6 RECEIVER INFORMATION AND MENU SETTING

Long press the "Power on,off"/" Mute "button  to start, and long press the " Calibration "button  to enter the interface of information/menu setting. The keyboard description and display examples are as follows:

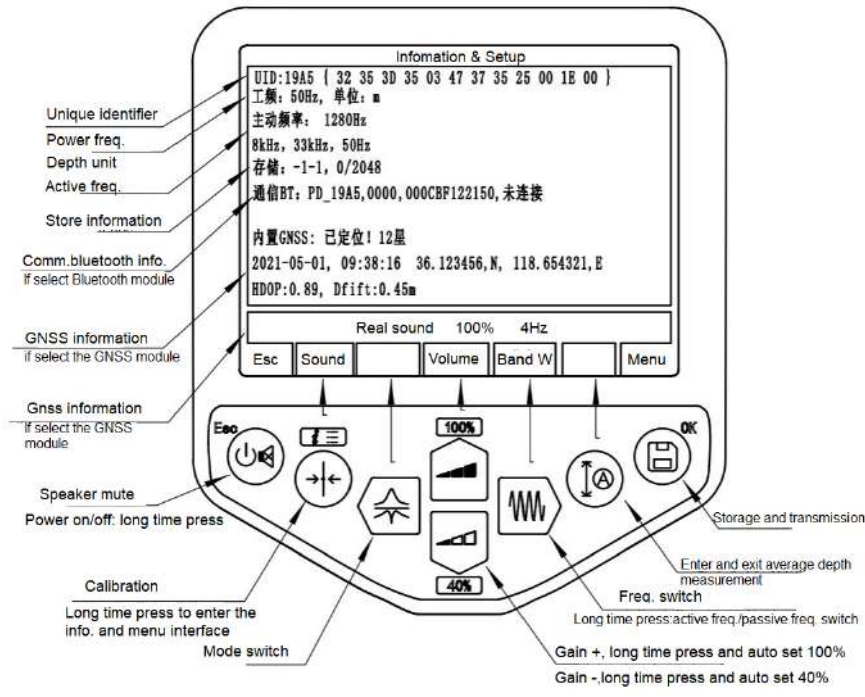



Fig.1-6-1 receiver information and menu display



Note:

- Long press the calibration key  to enter the information/menu interface.
- Click up/down to adjust the volume, press left key to switch sound mode,press Left to set the bandwidth ,press ESC to back to the previous menu.
- The unique device identification code UID cannot be modified.
- The power frequency, depth unit and active detection frequency is corresponding with menu setting values.
- If Bluetooth and GNSS positioning functions are not selected, Bluetooth and GNSS information will not be displayed.
- Menu: press ok  to enter the menu interface under the information and set interface.

Menu item:

<p>1. System function:</p> <ul style="list-style-type: none"> ● Save the setting ● Exit the menu interface ● English/Chinese switch 	<table border="1"> <tr> <td>Sys</td> <td>Mem</td> <td>50/60Hz</td> <td>m/ft</td> <td>Freq</td> <td></td> </tr> <tr> <td colspan="2">Save</td> <td colspan="4"></td> </tr> <tr> <td colspan="2">Exit</td> <td colspan="4"></td> </tr> <tr> <td colspan="2">—</td> <td colspan="4"></td> </tr> <tr> <td colspan="2">English</td> <td colspan="4"></td> </tr> <tr> <td colspan="2">Arabic</td> <td colspan="4"></td> </tr> <tr> <td colspan="2">French</td> <td colspan="4"></td> </tr> </table>	Sys	Mem	50/60Hz	m/ft	Freq		Save						Exit						—						English						Arabic						French																													
Sys	Mem	50/60Hz	m/ft	Freq																																																															
Save																																																																			
Exit																																																																			
—																																																																			
English																																																																			
Arabic																																																																			
French																																																																			
<p>2. Memory function:</p> <ul style="list-style-type: none"> ● Send all the saved data through Bluetooth (BT send all) 	<table border="1"> <tr> <td>Sys</td> <td>Mem</td> <td>50/60Hz</td> <td>m/ft</td> <td>Freq</td> <td></td> </tr> <tr> <td colspan="2">New project</td> <td colspan="4"></td> </tr> <tr> <td colspan="2">BT send all</td> <td colspan="4"></td> </tr> </table>	Sys	Mem	50/60Hz	m/ft	Freq		New project						BT send all																																																					
Sys	Mem	50/60Hz	m/ft	Freq																																																															
New project																																																																			
BT send all																																																																			
<p>3. Power frequency:</p> <ul style="list-style-type: none"> ● 50Hz or 60Hz optional 	<table border="1"> <tr> <td>Sys</td> <td>Mem</td> <td>50/60Hz</td> <td>m/ft</td> <td>Freq</td> <td></td> </tr> <tr> <td colspan="2"></td> <td>* 50Hz</td> <td colspan="3"></td> </tr> <tr> <td colspan="2"></td> <td>60Hz</td> <td colspan="3"></td> </tr> </table>	Sys	Mem	50/60Hz	m/ft	Freq				* 50Hz						60Hz																																																			
Sys	Mem	50/60Hz	m/ft	Freq																																																															
		* 50Hz																																																																	
		60Hz																																																																	
<p>4. Depth unit:</p> <ul style="list-style-type: none"> ● Unit optional m or ft 	<table border="1"> <tr> <td>Sys</td> <td>Mem</td> <td>50/60Hz</td> <td>m/ft</td> <td>Freq</td> <td></td> </tr> <tr> <td colspan="2"></td> <td>* m</td> <td colspan="3"></td> </tr> <tr> <td colspan="2"></td> <td>ft</td> <td colspan="3"></td> </tr> </table>	Sys	Mem	50/60Hz	m/ft	Freq				* m						ft																																																			
Sys	Mem	50/60Hz	m/ft	Freq																																																															
		* m																																																																	
		ft																																																																	
<p>5. Active detection enable:</p> <ul style="list-style-type: none"> ● Optional active frequency list ● Restore the factory default frequency ● Enable all frequencies 	<table border="1"> <tr> <td>Sys</td> <td>Mem</td> <td>50/60Hz</td> <td>m/ft</td> <td>Freq</td> <td></td> </tr> <tr> <td colspan="2"></td> <td>* 640Hz</td> <td colspan="3"></td> </tr> <tr> <td colspan="2"></td> <td>* 1280Hz</td> <td colspan="3"></td> </tr> <tr> <td colspan="2"></td> <td>128Hz</td> <td colspan="3"></td> </tr> <tr> <td colspan="2"></td> <td>512Hz</td> <td colspan="3"></td> </tr> <tr> <td colspan="2"></td> <td>* 8kHz</td> <td colspan="3"></td> </tr> <tr> <td colspan="2"></td> <td>* 33kHz</td> <td colspan="3"></td> </tr> <tr> <td colspan="2"></td> <td>* 82kHz</td> <td colspan="3"></td> </tr> <tr> <td colspan="2"></td> <td>* 197kHz</td> <td colspan="3"></td> </tr> <tr> <td colspan="2"></td> <td>Default</td> <td colspan="3"></td> </tr> <tr> <td colspan="2"></td> <td>All</td> <td colspan="3"></td> </tr> </table>	Sys	Mem	50/60Hz	m/ft	Freq				* 640Hz						* 1280Hz						128Hz						512Hz						* 8kHz						* 33kHz						* 82kHz						* 197kHz						Default						All			
Sys	Mem	50/60Hz	m/ft	Freq																																																															
		* 640Hz																																																																	
		* 1280Hz																																																																	
		128Hz																																																																	
		512Hz																																																																	
		* 8kHz																																																																	
		* 33kHz																																																																	
		* 82kHz																																																																	
		* 197kHz																																																																	
		Default																																																																	
		All																																																																	

Note:

1. Selection of power frequency, depth unit and active detection frequency: Menu items marked with an asterisk (*) are enabled items, and items not marked with an asterisk (*) are prohibited items. Press OK button  to switch the enabled and prohibit.
2. Too many frequencies will cause tedious operation. It is recommended to enable only the commonly used frequencies and enable other frequencies when necessary.
3. 50 Hz (or 60Hz) for power cable detection, 100Hz (or 120Hz) for impressed current cathodic protection (CPS) pipeline detection.
4. If Bluetooth and storage function are not selected, there is no sub-item display under the main menu of storage function.
5. After setting, enter the main menu of the system to select Save, and press OK  to save the setting content.
6. Press and hold the storage key  to turn on the device. Under the storage function menu, there are Bluetooth heartbeat, data clearing, and memory initialization functions.

2. GENERAL SIGNAL OUTPUT METHOD

There are three methods of transmitting signals to the pipeline: direct connection, clamp coupling and radiation induction. As a general introduction of these methods, this chapter is general introduction of these methods and for cable detection sometimes there are particularity, which will be specifically introduced in Chapter 3.

2.1 DIRECT CONNECTION MODE:

This method is to connect the output cable directly to the metallic pipe and inject the signal. It adapts the metallic water pipeline and gas pipeline, telecom cable, power cable, cathodic protection pipe testing point and other access points, or other line characteristics continuous metal structure. Current from transmitter flows into the earth through pipeline access points, or distributed capacitance between earth and pipe, and at last return to the transmitter. This current on the pipe will generate electromagnetic radiation. Receiver will detect the pipe by receiving this magnetic field information.

Compared with other mode, this mode will get the max. transmission current for better testing result. We suggest to use this mode condition permit.

2.1.1 Direct connection mode connection diagram

*Connect the 5-cores red plug into the output socket of the transmitter

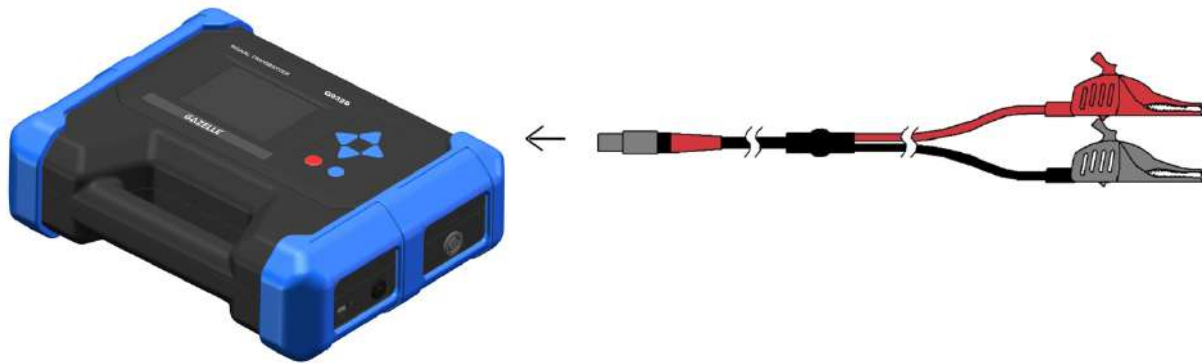

Fig.2.1.1 Main unit and accessories cable connection diagram

2.1.2 Direct connection mode wiring diagram

Connect the red alligator clip with the exposed metallic part of the pipe and connect the black alligator clip with the inserted grounding rod. If grounding cable is not long enough use the optional extending line.

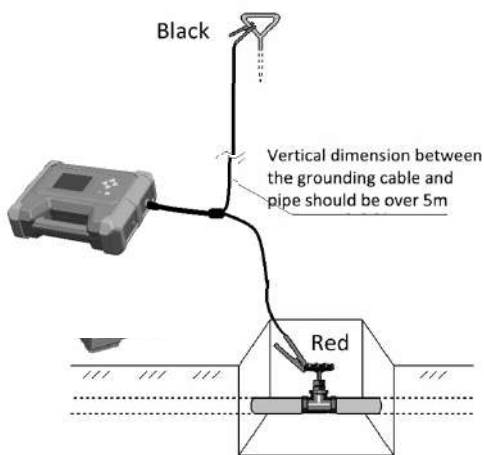

Fig.2.1.2 Direct connection mode wiring method



- Grounding rod position should be over 5m from the pipe and try to make the black grounding cable perpendicular to the pipe direction.
- Don't clamp the black clip with the water pipe line or other pipe to avoid the interference to the target pipe detection.
- Use radiation detection mode to check whether other pipes below grounding rod and target pipe to avoid interference .
- Make sure well connection. If there're insulating coating or seriously rust on the pipe joint, to clean it before test to make sure well connection of red alligator clip and pipe metallic part.
- If different pipe sections are insulated, or it's insulation between pipe and fitting, the direct connection mode is unusable. Or to make the insulation parts electrical connection before testing. Checking the transmitter output current, if current is too small to test, it's possible that the pipe has insulation.

WARNING !

transmitter max. output voltage is 150vpp! don't touch the output clip and target pipe when working!

2.1.3 Interface introduction and pipe voltage measurement

Long time press ON/OFF button  to power on the transmitter. Device will check accessories automatically and enter the direct connection mode.

Under this mode, the device will first test pipe voltage and display on the screen:

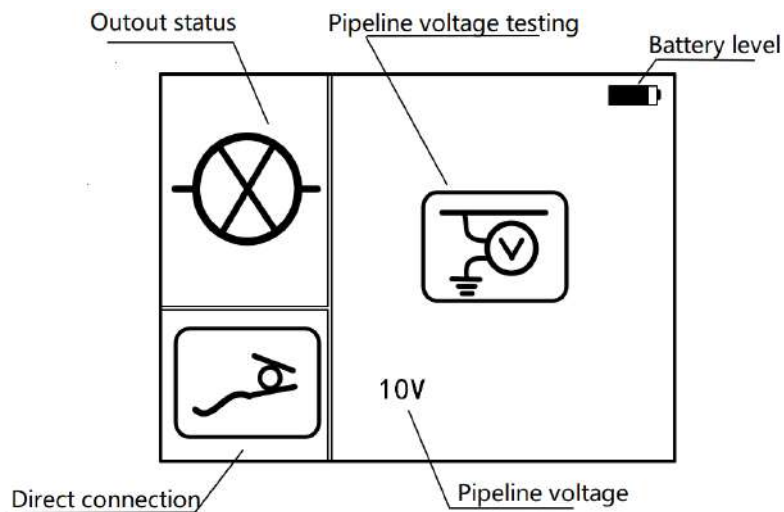

Fig.2.1.3 Pipeline voltage testing interface

If pipe voltage over limitation 50V, device will keep the voltage measurement interface and display the alarming mark as below:

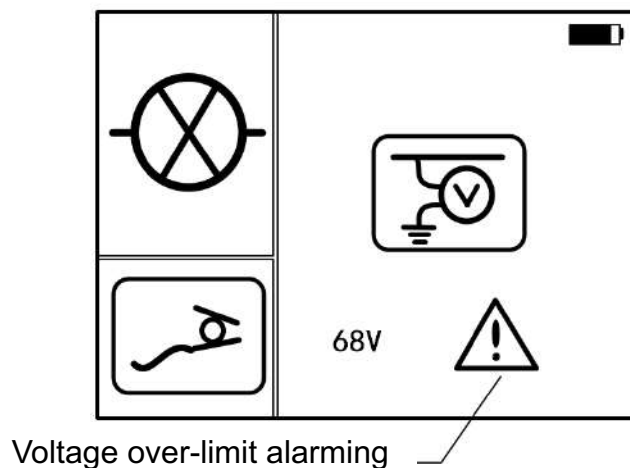

Fig.2.1.4 Over voltage alarming interface

If voltage is normal, device automatically outputs signal after several seconds. Screen display as below

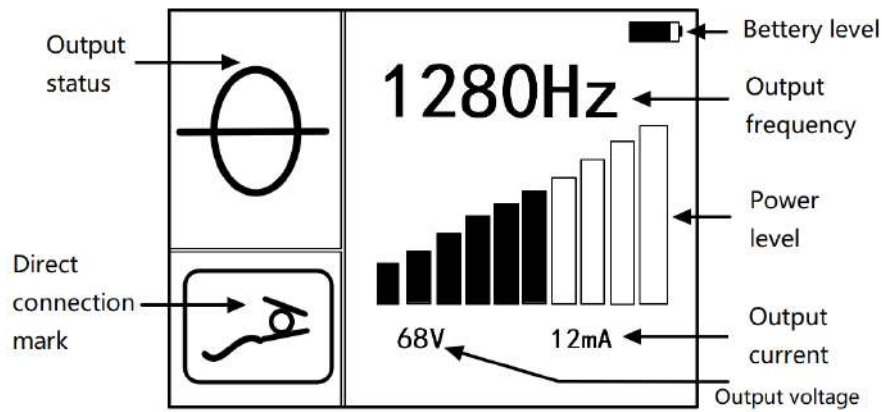

Fig.2.1.5 Direct connection interface

2.1.4 Frequency selection

Press frequency key Ⓜ to select the transmitting frequency. Six frequencies could be selected: 640Hz, 1280Hz, 8kHz, 33kHz, 82kHz, 197kHz. Default power on frequency is 1280Hz. Some frequency selection suggestions:

- Common good grounding cable and pipe, suggest to use the default 1280Hz. It can complete most of the testing requirements.
- Choose low frequency such as 640Hz&1280Hz, to do long pipe route tracing. Low frequency is long transmission distance and not easy to induce to other pipe. And this two frequencies is complex frequency support tracing error/correct indication.
- Common pipe tracing use the middle-high frequency (8Hz). This frequency spread far and not easy to induce to other pipe.
- For high resistance pipe, such as the cable core with floating opposite end, pipe with anti-corrosive coating, cast iron pipe, we suggest to use high frequencies, such as 33kHz, 82kHz or 197kHz. The high frequency radiation capacity is high but near transmission and easy to induce to other pipe.
- For normal detection we suggest to choose low frequency first.

2.1.5 Adjust output power level

Press output decrease button ⊖ and output increase button ⊕ to adjust the output levels (total 10 levels). The right down corner will display the output voltage and current.

Adjust output levels according different requirements:

- Big current contributes to detection stabilization and veracity.
- If high frequency (8Hz and above) and shallow depth (in 1 meter), high current output will bring receiving saturation distortion to make receiver nonlinear responding and depth measurement error. And now should decrease output level.
- Decrease output power is contribute to extend battery using time.

2.2 CLAMP COUPLING MODE:

This method is used for the naked Pipelines while it is difficult or unable to reach the metal part, and both ends grounded, especially useful for the power cables.

Signal transmission of clamp coupling mode equals to a transformer: clamp magnetic core is transformer magnetic core, clamp internal winding equals to transmitter primary, pipe-earth loop equals to secondary (single-turn), transmitter offer primary current, pipe-earth coupling generate secondary current. The coupling current is related to the loop resistance. The smaller resistance the bigger current, the bigger resistance the smaller current, until it's too small to detect.

The clamp coupling mode is easy to use and no need electrical connection so no effect to pipe normal running and will reduce the induce to other pipe. But the coupling current is smaller than direct connection mode, require pipe both ends good grounding, this doesn't apply to all cases.

2.2.1 clamp connection

Assemble transmitting clamp as below:

Use the red connection cable to connect the clamp and the transmitter output port.

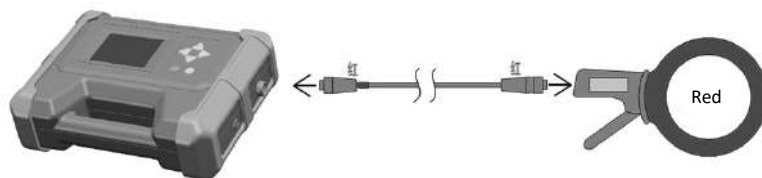

Fig.2.2.1 Clamp coupling accessories connection diagram

2.2.2 Clamp the pipe naked part as below:

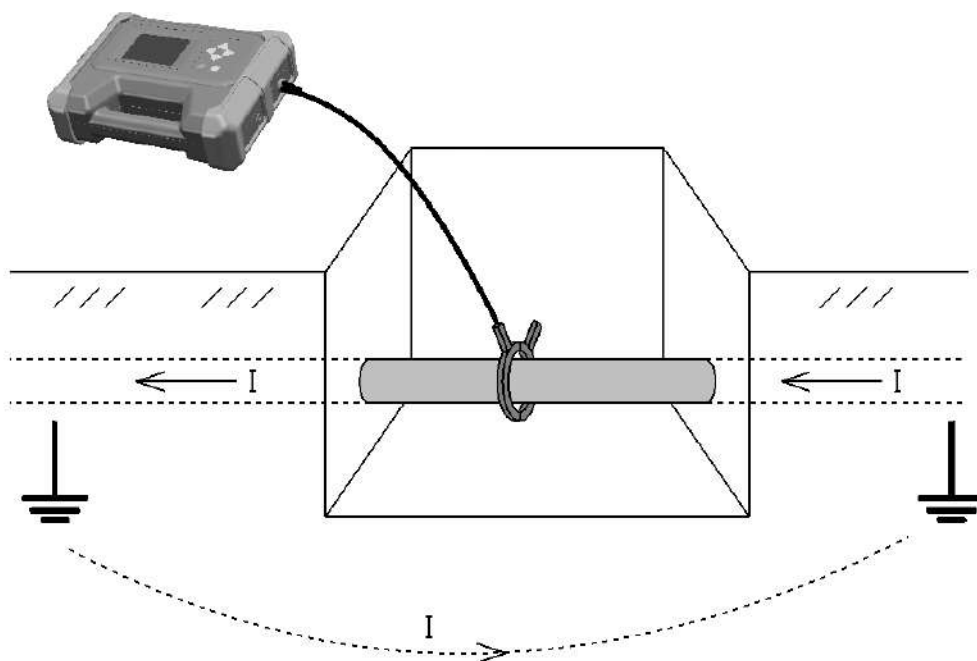

Fig.2.2.2 Clamp coupling mode wiring



- Make sure that the both ends of the pipe/cable are grounded. The grounding can be continuous grounding (shield grounding) or both-end grounding (high voltage power cable shield grounding at both ends).

- Different segment of the cable/pipe, or fitting with tube maybe insulated, we need to make them electrically connected, or we can not use this method.
- Judge whether it can induce signal on the pipe/cable only by the receiver detection result. If can not detect properly, we need to use other methods.
- Make sure the clamp is fully closed when we use it to clamp the pipe/cable. Clear the Clip before using, to make sure there is no other things between or it is rusted.

2.2.3 Interface introduction:

Transmitter power on and will automatically check the accessories and enter the clamp coupling mode. Screen display as below:

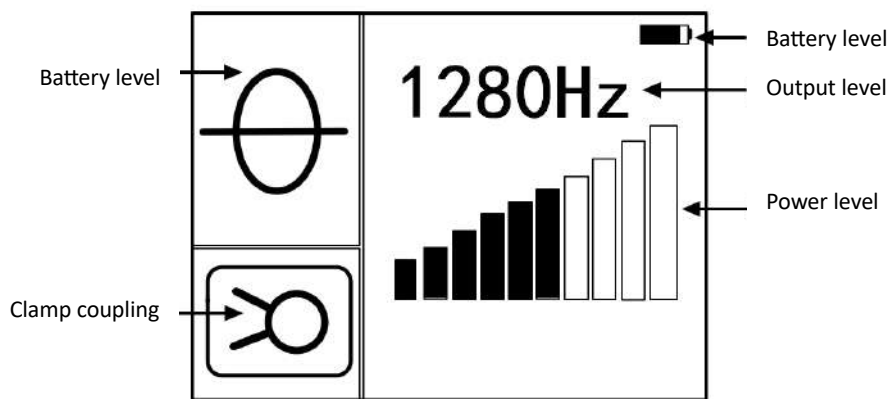

Fig.2.2.3 Clamp coupling output interface

2.2.4 Frequency selection

Press frequency decrease button (⊖) and frequency increase button (⊕) to choose the transmitting frequency.

Total five frequencies: 640Hz, 1280Hz, 8kHz, 33kHz, 82kHz. Power on default 1280Hz.

Clamp coupling mode frequency selection method is same as direct connection mode.

2.2.5 Output power adjustment

Press output decrease button (⊖) and output increase button (⊕) to adjust the output levels (total 10 levels).

The current coupled to the pipe is much lower than direct connection mode, so to use the max. level output.

Clamp coupling mode can't display the coupled voltage and current.

2.3 RADIATION MODE:

If there is no bald part for the pipe, or detection before excavation, we need to use Radiation mode. The Transmitter use the internal radiation loop to radiate high frequency magnetic (primary), the metal tube-earth loop will induce current, and the induced current will radiate magnetic again (secondary), the receiver can receive secondary magnetic for the pipe detection.

The Radiation mode is easy to use and no cable connection is needed, especially useful for the detection of pipe that has no bald part. The disadvantage is that it has low induced current, specially if the pipe is deep (over 2m). And it will induce all the pipes and output signal so it will be not useful for special pipe detection.

2.3.1 Transmitter position

When use the radiation mode, no need to connect any accessories and device will automatically identify as Radiation mode.

For pipe route tracing: put transmitter vertically above the targeted pipe. Matched with receiver during the detection. Adjust the direction and location accordingly during the detection.

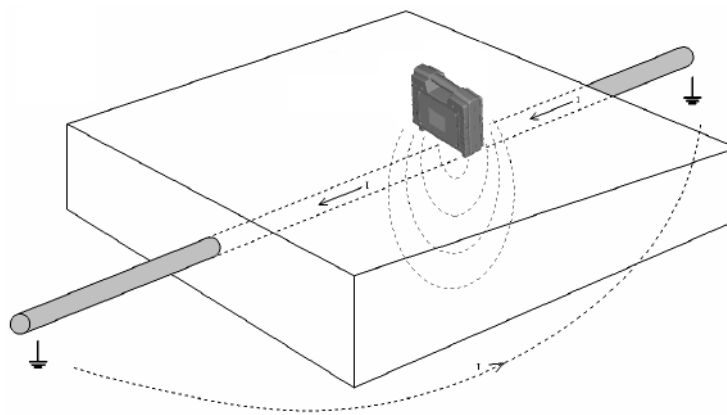

Fig.2.3.1 Radiation mode measurement diagram

For pipe detection: this needs two people to cooperate for the detection, keep the Transmitter and Receiver at certain distance and move them simultaneously, they should have same direction.

Please refer to page 38 Radiation detection.



- Make sure that the both ends of the pipe/cable are grounded, or it can not induce signal. The grounding can be continuous grounding (shield grounding) or both-end grounding (HV power cable shield grounding at both ends).
- If the pipe is well insulated and it is not grounded at either end, we can not use the Radiation method. For example, some low voltage cables have no metal shielding, or the shielding is not grounded, we can not use this method.

- Can not put the Transmitter on the metal well covering or concrete with steel bar reinforcement, because the signal will be isolated by them.
- The transmitter will transmit signal not only to the targeted cable/pipe, but also to other medias, so we need to keep some distance between the Receiver and Transmitter.

2.3.2 Interface introduction

When transmitter power on, it will automatically enter the radiation mode if no accessories. Display interface as below:

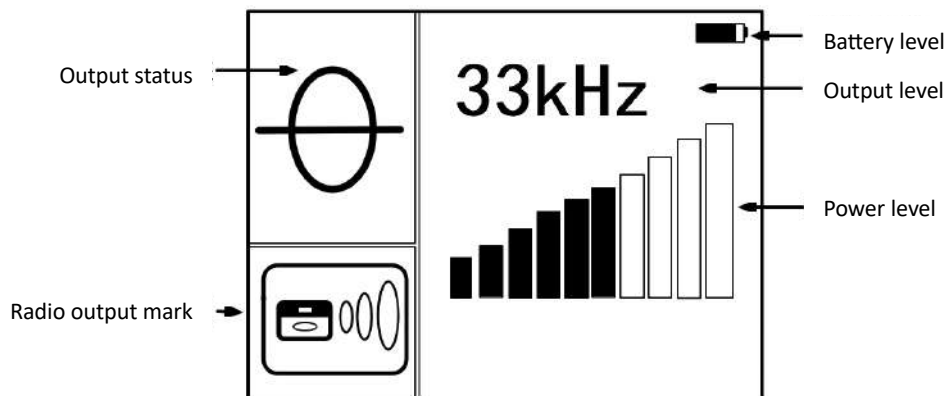



Fig.2.3.2 Radiation mode measurement diagram

2.3.3 Frequency choice:



Press frequency decrease button  and frequency increase button  to choose the transmitting frequency.

Total three frequencies: 33kHz, 82kHz, 197kHz. Default frequency is 33kHz.

Notice:

- High frequency has the feature of better induce effect, but short propagation distance and easy to induce signal to other pipe.
- Low frequency can propagate long distance, not easy to produce interference, but the induce effect is not good.
- For detection of high resistance pipe, we should select high frequency when it's difficult to induce suitable signal.

2.3.4 Power adjustment

Press output decrease button  and output increase button  to adjust the output levels (total 10 levels).

Use low output level will decrease to induce to other pipe and reduce the receiving- transmitting distance.

If detect deeper pipe, we suggest to rise output level.

The transmitter can't test and display the pipe induced current value, so we have to repeated attempt according detection effect.

3. SIGNAL TRANSMITTING METHOD FOR CABLE DETECTION

The cable route tracing and the cable identification is very important function of pipe/cable detection. Compared with the single and continuous metal structure of pipe, the cable is composed by several cores and metallic armor. These construction and use differences make signal applying method different and different connection method will make different electromagnetic field then different detecting result. So this chapter will introduce the cable detection signal transmission method individually.

3.1 SIGNAL TRANSMITTING METHOD FOR DEAD CABLES

3.1.1 Basic connection method: Core wire-Earth connection

Core wire-Earth connection is the best connection method for route tracing and cable identification for dead cables. It will give full play to the device function and reach max. anti-interference performance. Refer below fig.3.1.1

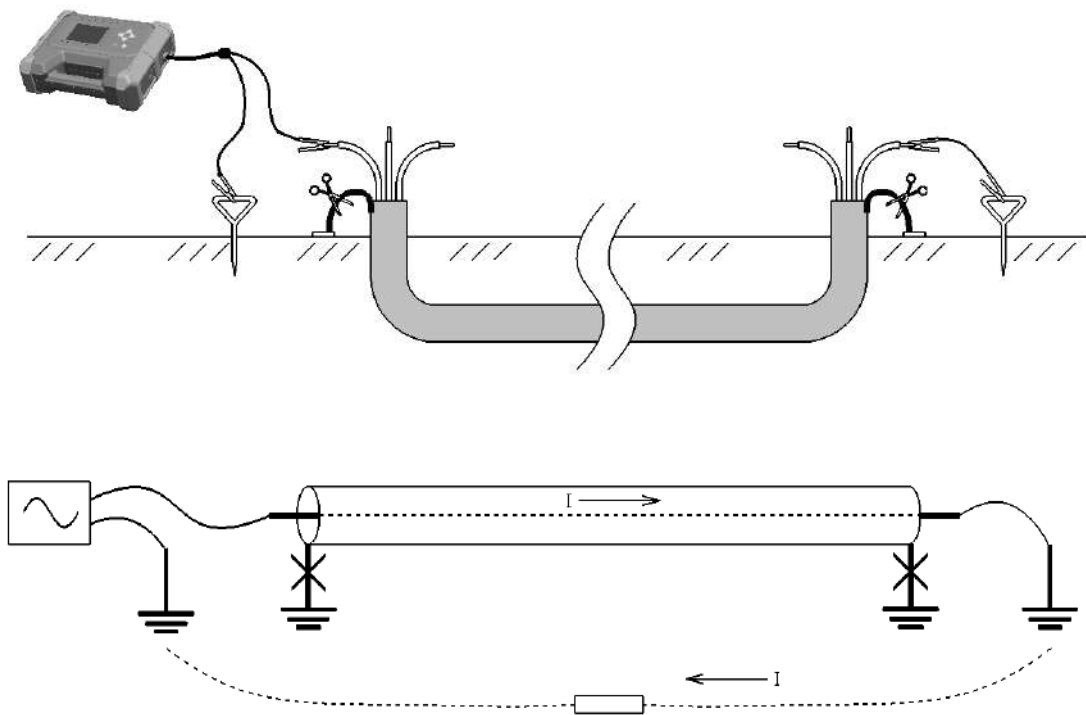

Fig.3.1.1 Core wire-Earth Connection Method

Disconnect the ground cables of both terminals of cable sheath, also disconnect the Null line OF LV cable and Grounding line. Clamp one good phase with the RED CLIP , and clamp the grounding rod with BLACK CLIP. At the cable opposite end, connect the core line with the grounding rod insert in the earth.

Attention: Use grounding rod, do not use grounding network! At least use grounding rod for the other end of the conductor, and the grounding rod should be away from the grounding network. Otherwise the earth wire back flow will effect the detecting result.

The current travels from the Transmitter, flows through the core wire and earth at the far end, then travels back to the transmitter. This connection method will make the receiver induce strong signal with clear character for device anti-error tracing indication.

There will be strong signal flows through the well isolated conductor, it will not flow to nearby pipelines, especially the crossing metal pipelines, it specially applies to the route tracing under complex environment. In addition, the cable is grounded, so the signal voltage flow through cable is low, which can not interfere other instruments.

Because there is distributed capacitance between conductor and earth, the current will attenuate when flows from this end to the other end, but if it is well earthed, the leaked current will be very low, we can ignore it.

The shortage for this connection method is that it needs to disconnect the grounding line for the both ends of the cable and seems a little too complicated.

3.1.2 Sheath-Earth Method

As below Fig. 3.2 shows, loose grounding cable of the sheath of the near end of the cable, also loose the earthing of Null line and Grounding line of the low voltage cable, keep the sheath of the cable grounded at the far end. Then to apply signal between the sheath of the cable and the Grounding Rod (Do not use grounding network), and keep the conductor hung in the air. The current travels from Transmitter, then flows through the sheath and goes to the earth at the far end, then travels back to the Transmitter. This way, there will be no shielding, the signal to the ground is strong, and the signal character is clear. Also, because the distribution capacitance exists, the signal attenuates from the near end to the far end.

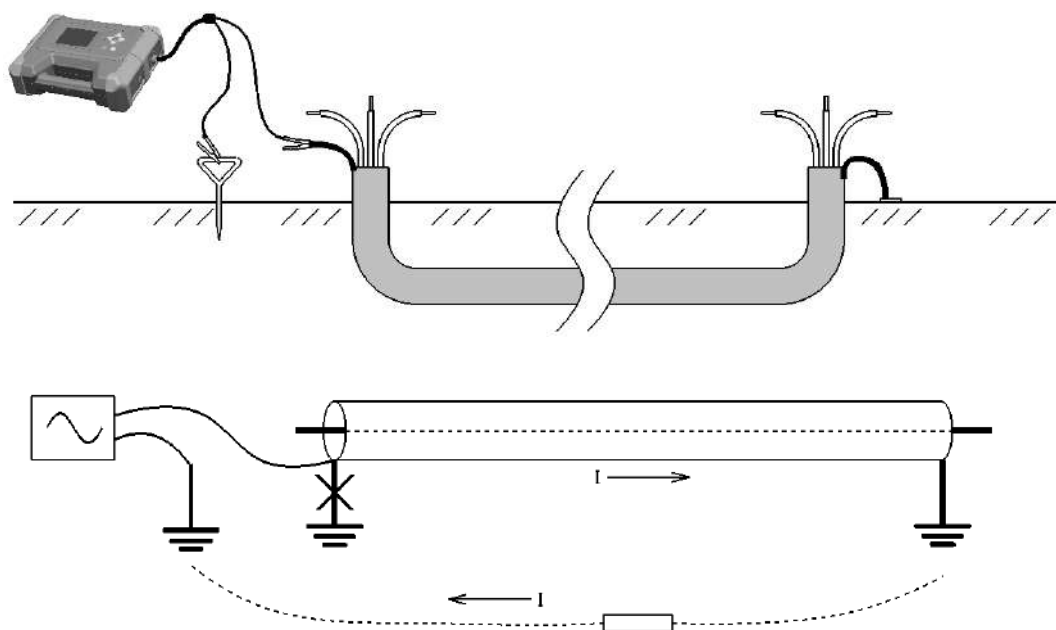

Fig.3.-1-2 heath-Earth Method

The potential problem for this connection method is if sheath breakage, the current may go to the earth at the breakage point to make the signal received will have a sudden decrease at the breakage point, and the decrease level depends on the grounding resistance at the breakage point.

3.1.3 Phase-Sheath Method

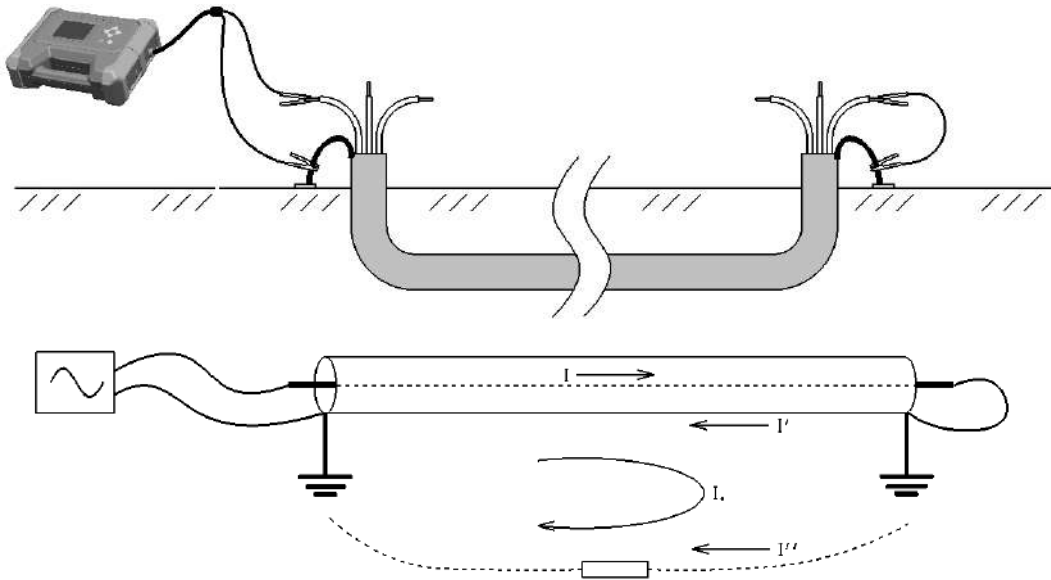

Fig.3-1-3 Phase-Sheath Method

As above fig.3-1-3 shows, signal is applied between cable one phase and sheath, short the far end phase and sheath, keep the both ends of the sheath grounded.

If there is one cable, the current will flow from the Transmitter to the conductor, and return through sheath and earth. Because the sheath has low resistance while earth has high resistance, most of the current will flow back via sheath and only little returns through earth. Because the direction of conductor current and sheath current reverse, the difference equals the virtual current which generates electromagnetic signal in external with some distance. The value equals the resistance current back through the earth. Because the induction of Conductor-Sheath loop and Sheath-Earth loop, the current will also be generated by electromagnetic. The end effect is the virtual current equals the vector addition of earth loop resistance current and induction current. For different field condition, the virtual current is about only a few percent to lower than twenty percent of the injected current.

If there're other same path cables (with same end positions), the return current will be shunted by these cable sheaths. For example, if there're three cables in same path, the sheath return current of every cable is $1/3$. The virtual current is positive and the value is about $2/3$ of the injected current, while the nearby current is passive and value is about $1/3$. Refer below Fig. 3.4

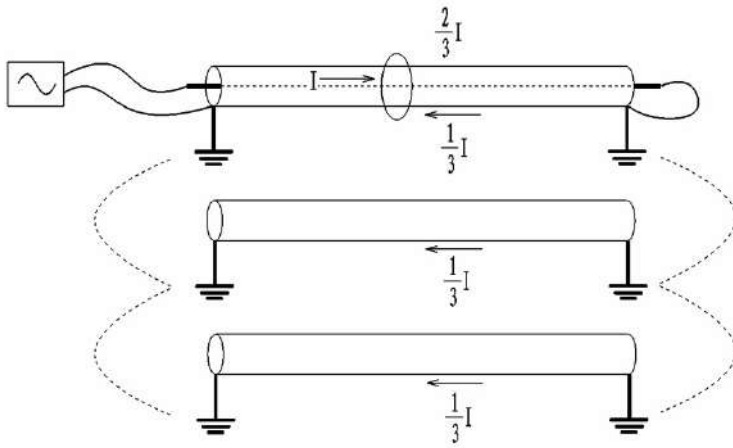

Fig.3-1-4 Shunt effect of parallel cable

The Phase-Sheath method is easy to connection, no need to loose the grounding cable. But when multiple cables lay in same path, the signal difference of different cables will not quite different not easy to distinguish only by signal amplitude.

When single cable lay, the effective current will sharp decrease, signal will be weak and effective current has induction current so the target cable has same induced signal phase with nearby pipes. If use the complex frequency, it maybe difficult to eliminate the disturbing signal according the current direction.

3.1.4 Phase-Phase Method

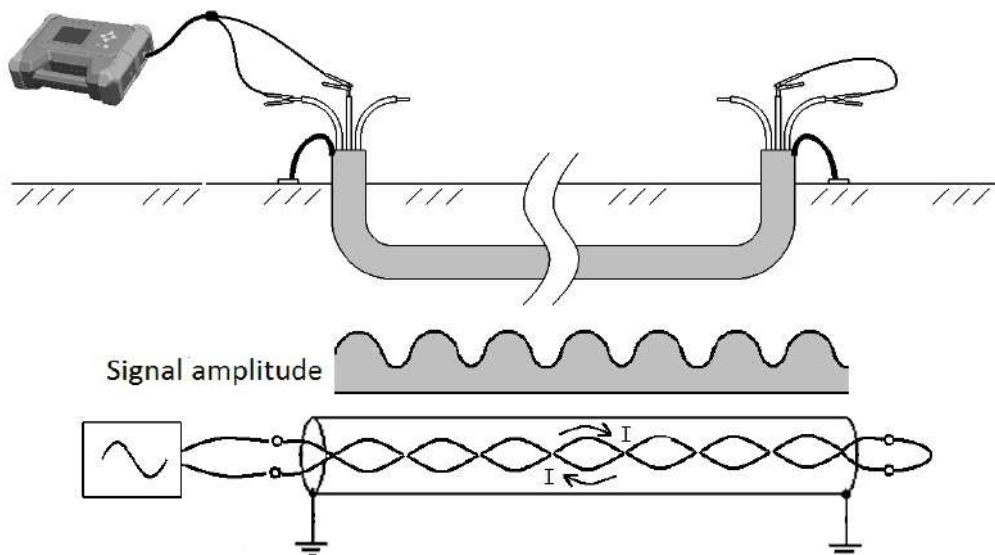

Fig.3-1-5 Phase-phase method

As above fig 3-1-5 shows, the signal is injected between two phases of the cable, and the two ends of cable short circuit. The two phases of cable is interior twisting, so the current value is same but in opposite directions. Though the two phases are near each other, the distance of two phases and receiving coil is small difference, and the magnetic field direction here will have

opposite direction. But the magnetic field strength is not same because the distance difference, so most parts will be counteracted. The balance parts will be weakened by the metallic sheath shielding effect and at last received by device. Because the twisting, signal will travel long with the cable path and with period and direction variation.

In one twisting period, the external radiation flux will full canceled out by the 360° continuous change, so no induced current in the sheath-earth loop.

Because the effective signal is very slight, use high frequency will be easier to detect than the low frequency. The phase-phase connection method can't use the current direction test method of receiver to eliminate nearby pipeline interference.

3.1.5 Select frequency

- Normally, use the default 1280Hz can fulfill the detection of most of the cables/pipes except phase-phase connection. It's low frequency and with long transmitting distance so not easy to induce to other pipe. Also the receiver has better receiving effect for this frequency.
- For long distance cable/pipe (longer than 2-3Km), if use the 1280Hz, there will be very big attenuation if long distance. So we suggest frequency 640Hz.
- 640Hz and 1280Hz is complex frequency, under this two frequencies, device support tracing right/wrong indication.
- For phase-phase connection, we should select high frequency (8kHz,33kHz,82kHz or 197kHz).

3.2 SIGNAL TRANSMITTING METHOD FOR LIVE CABLES

3.2.1 Clamp coupling method

This is an ideal detection method for the live cables, no need to change the cable and very safe to operator; there is signal on the whole length of the cable, and no distance limitation.

The both ends of the cable sheath should be grounded, or the coupling current will decrease while grounding resistance increases.

We can not use the clamp coupling method if the both ends are not grounded, or the sheath is broken.

- Clip the cable

As below fig.3.2.1 shows, this method is useful for the detection of common three-phase power cable. Connect transmitter output with clamp and use the clamp to clip the cable (not clip the part above the grounding line). The clamp equals to transformer primary, cable metallic sheath-earth loop equals to secondary (single-turn). The coupling current is related to the loop resistance. The smaller resistance, the bigger current.

The cable current from clamp coupling is small. To strengthen detection effect, we suggest choosing big output level.

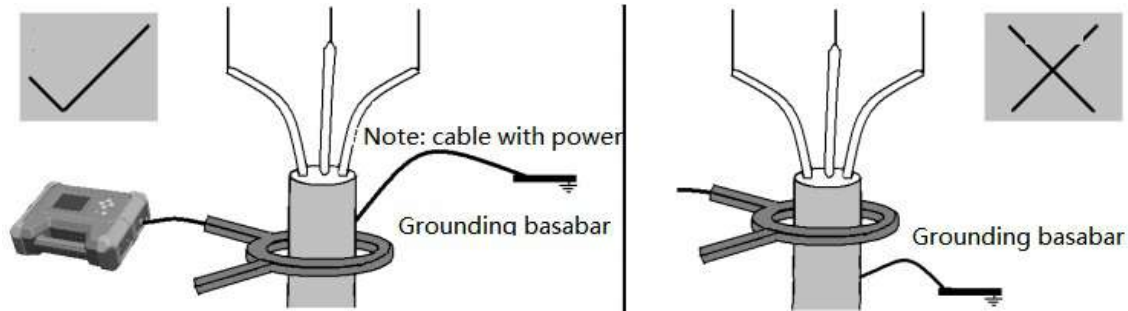

Fig.3-2-1 Clamp coupling method 1 (to clamp the cable)

- Clip the cable sheath grounding line

This method is useful for detection of ultra high voltage single core live cables. Because it has strong power current flows the cable phase, and it has no three phase offset effect like the three-phase cables. If we clamp the cable itself using the Clamp, it is easy to have magnetic saturation and signal is not transmitted. That is why we need to clamp the sheath grounding cable.

Such single core cable sheath will crossing connect at some distance, the signal also will flow from one phase sheath to an other sheath. Notice it when detection. For three cores belted cable, if not suitable to clamp the cable, clip the cable grounding line is also useful. But during some special situation, this will make signal feature unpredictable

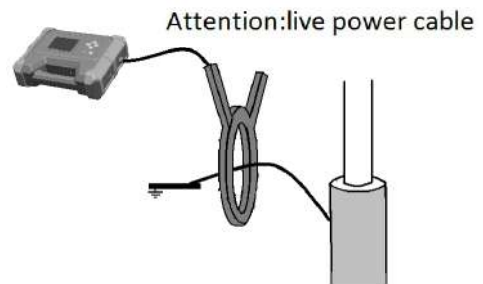

Fig.3-2-2 Clamp coupling method 2 (to clamp the cable grounding line)

3.2.2 Null line/Ground line/Shield Injection method

This method is used for detection for the live low voltage cables, because most of the low voltages shield is not grounded, or the shield is not continuous, or it is not very well grounded, we can not use Clamp Coupling method.

This method no need to modify the cable, and because inject the high frequency, it will not effect the running line.

At the operator end, clip the null line, grounding line or shield with the red clip, and the black clip to the grounding rod. It is as Fig. 3.8 shows.

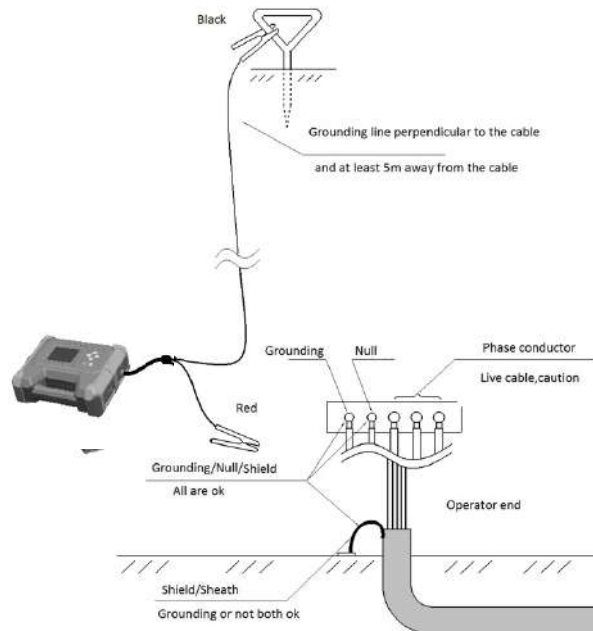

Fig.3.2.3 Null/Ground/Shield Injection Method



● **The cable is live, there is power, the operator needs to be competent to do this work for cable connection.**

- Please do connect the Transmitter at the user end. If inject signal in the transformer end, signal will be injected in all the outlet cable and difficult to distinguish the target cable.
- The position of the ground rod: it should be at least 5m away from the pipe or cable, and keep the black cable perpendicular to the cable path.
- If the null cable is not grounded at the operator end, please preferentially use Null to inject signal.
- The shield maybe discontinuous for the low voltage cable, if the signal injected is too weak, or the signal is interrupted during the detection, we can use the Null/Ground method to inject signal.
- When we detect the live high voltage cable, the signal is very weak or we can not receive signal using clamp coupling method, this shows that the shield ground resistance is too high at the double ends, for this condition, we can use Shield to inject the signal.
- For single conductor ultra high signal live cable, sometimes the clamp coupling method maybe not effective, we can use Shield Injection method.

4. ACTIVE DETECTION

Active (source) detection requires the selection of appropriate methods to inject signal to the pipeline as described in Chapters 2 and 3.

4.1 PIPE ROUTE TRACING

4.1.1 Install depth measurement auxiliary sensor

(if optional) :If a depth measurement auxiliary sensor is selected, insert it into the corresponding installation position of the receiver as shown in the figure on the right.



Fig.4.1.1 Receiver appearance

4.1.2 Receiver interface introduction

Long press the receiver Switch/mute button to turn on the power of the receiver. The screen display and keyboard description are as follows:

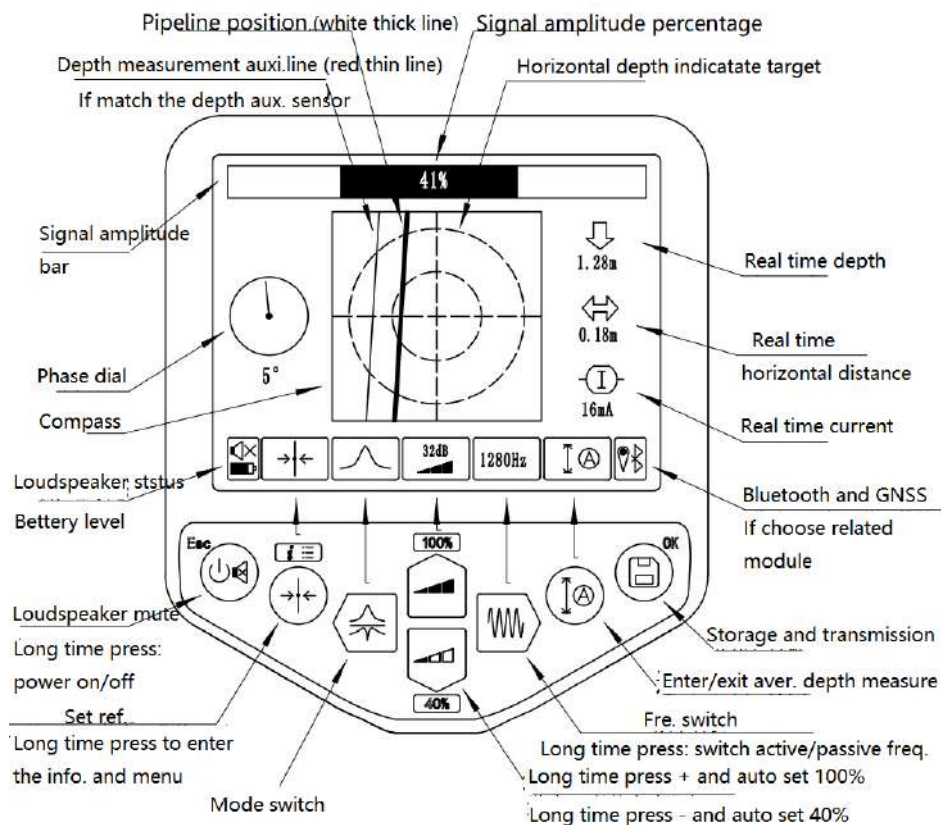



Fig.4.1.2 Receiver interface reference

4.1.3 Setting receiving frequency

Press frequency decrease button  to select the receiving frequency. Make sure transmitting and receiving frequency is same.

Below frequencies for selection:

- Complex frequency: 640Hz,1280Hz,support to do error-proof tracking prompts.
- Single frequency: 8kHz,33kHz,82kHz,197kHz.

If certain required frequencies cannot be switched, long press the calibration key to enter the interface of information and menu setting to enable the required frequencies, as shown in Section 6 of Chapter 1: Receiver Information and Menu Settings (P6-P7).

Note: Long press the frequency key  to switch active frequency and passive frequency.

4.1.4 Select mode

Press Mode button  to choose wide peak mode, narrow peak mode, valley mode,peak-valley scanning and history curve mode.

- Wide peak mode:

Signal response of the lower horizontal coil. In the wide Peak mode, the signal right above the cable/Pipe is the strongest. The advantage for this method is with high sensitivity, and wide range; the disadvantage is that it responding curve changes slowly, and not easy to distinguish the parallel cables.



- Narrow peak mode:

Differential signal response of lower horizontal coil and upper horizontal coil. Similar to the wide Peak method, it has sharp responding curve, easy for parallel cable/pipe detection; the disadvantage is that it has low sensitivity.



Valley mode:

- Signal response of the vertical coil. The signal just above the cable/pipe is weakest, and it changes rapidly besides the cable/pipe. The advantage of this method is that it is easy to precisely pinpoint; the disadvantage is that it has low anti interference ability.



- Peak-valley scanning mode:

Record the horizontal coil and vertical coil signal amplitude response, It could be use to distinguish the testing result correct or not.

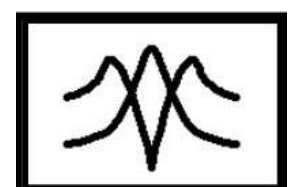

- History curve mode:

It will record the horizontal coil and vertical coils signal amplitude history curves, and could distinguish the peak value and valid value coincidence or not to find the pipe position. It also will be used to detect multiple pipes by the passive method. It applies to phase-phase short circuit fault detection.

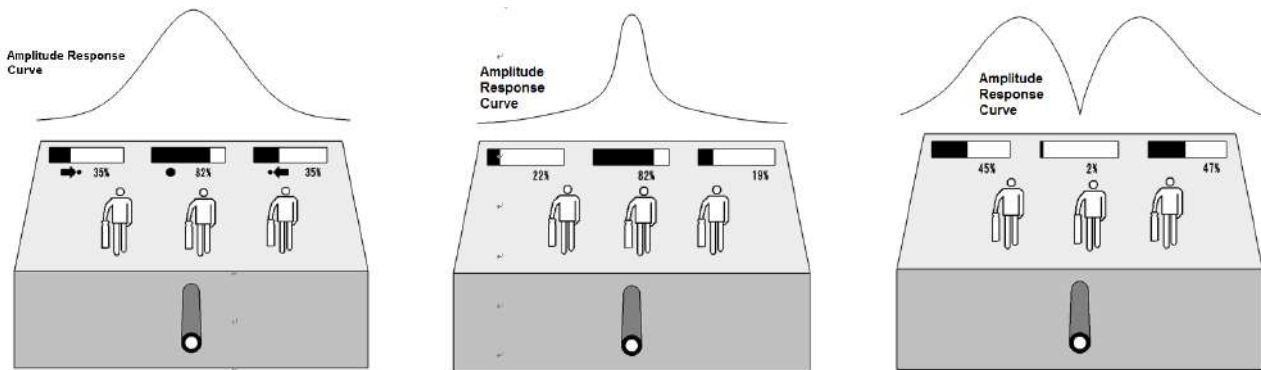

Fig.4- 1.4 Signal responding under different mode

4.1.5 Adjust gain

Short press Gain +/- button to adjust the gain value. The gain decibel value is displayed right below the screen.

Long time process Gain + button to do auto gain adjustment to 100%

Long time to press Gain- button, the gain will be auto 40%

4.1.6 Pipe tracing according signal amplitude and audio (traditional method)

We need to begin to locate the pipe at the Transmitter side but not be effected.

- Use the clamp method and radiation method. The transmitter will interfere the detection if the distance is too near, so we need to keep some distance. The interfere is related of the transmitting power and frequency. The bigger power and frequency the stronger interfere.
- The minimum distance between the Transmitter and Receiver needs to be determined by experiment, normally of 5m for the Clamp method and 20m for radiation method could be seen as suitable distance without interference.

Use the Peak mode (Wide Peak or Narrow Peak) to find the point where signal is strongest, and begin to trace the cable/pipe at this point. Swing the Receiver, the signal amplitude will change as Fig. 4.1.4 shows, follow the peak position (highest point at Peak mode) or null position (lowest point at Null mode), till we get the route of the cable/pipe.

Use Null mode, we can quickly locate the trace, the weakest point is right above the pipe, at the both sides of the cable/pipe, the signal will increase obviously. But because Null mode is easy to be interfered, we need to change to Peak mode after some time to ensure the tracing result.

Receiver loudspeaker sound output can reflect the current signal strength, which is helpful to track line, but this function is mainly to serve the users accustomed to using traditional path instrument, and use a compass function, can more quickly intuitively track line and generally do not need to voice prompt, so the loudspeaker is off as default.

If necessary, short press switch/mute key  to turn on or off the speaker.

4.1.7 Compass oriented quick tracing method (new method)

When receiver nearing the pipe above, compass in the middle of screen will directly display the pipe position below the receiver and with a middle arrow points to the pipe. If receiver right above the pipe, the arrow will change to a dot. This function will do quick trace for the underground pipe.

Observe the compass indicates the line position and Angle of the pipeline, and adjusts the receiver position accordingly. When the line is vertical and located in the center of the compass, the receiver is located directly above the pipeline.

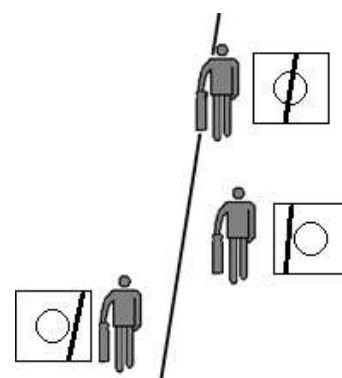

Fig.4.1.5 Compass demonstration

Fig.4.1.5

Attention:

- If nearby pipe has strong signal, and the receiver is near, compass still indicate but please notice, this will display the nearby pipe but not the target pipe.
- If nearby pipe has large interference, the compass will have deviation. If need accurate position, please refer below the 3rd segment Accurate positioning.

4.1.8 Anti error tracing (Correct/ Error tracing indication)

The nearby pipe usually has lower current than the targeted pipe when detecting, but the response of the Receiver also has some connection to the depth of the pipe/cable, if the targeted cable/pipe is deeper than the nearby cable/pipe, it will be difficult to tell which one is having lower current.

Through test the current phase position will have correct/error indication and achieve the Correct/Error tracing function.

When using the tracking anti-error function, the receiver measures the current phase in real time and compares it with the reference phase.

The process of recording the reference phase is Set Ref., and the set data will not be lost when device is turned off.

Note: Use the Correct/ Error indication function, the work frequencies should be 640Hz/1280Hz. If use other frequencies, the device will not display the phase dial.

At the distance close to the transmitter but not disturbed by it (such as 5-10m), clearly detect the position of the target pipeline. Just above it, back to the transmitter and facing the end of the pipeline, short press the Set ref. key ⊕, and the corresponding position just above the calibration key will turn orange and display a question mark:?

If press other keys, the Set Ref. operation will be canceled. If press the Set Ref. key ⊕ again, it will display: OK! and indicating that the calibration is completed, and the current phase returns to zero, then below will display : the phase dial pointer points to the top, and the Angle under the dial changes to 0°. After set ref., the current phase measurement shall take this as the reference.

During the process of detecting pipe, check phase dial and if almost the pointer points above, it means device above the target pipe. If pointer always points to below and appear ‘?’ mark, it means tracing nearby pipe. Refer below Fig.4.1.6 The nearby pipe signal amplitude maybe big or small and also will have compass indication.

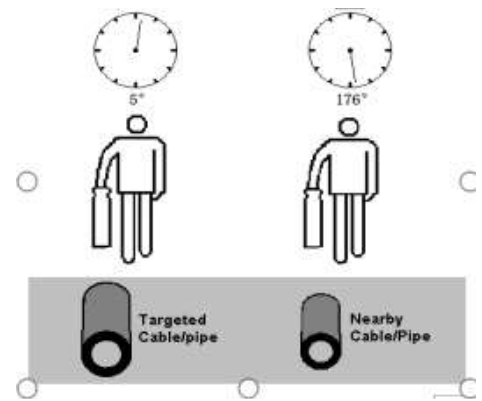

Fig.4.1.6 Correct/ Error tracing indication

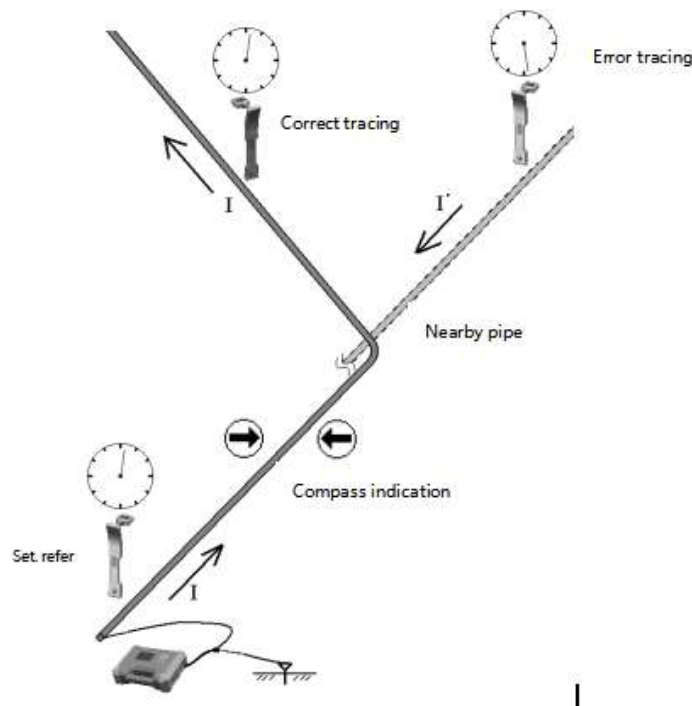

Fig.4.1.7 Anti-error tracking process schematic

4.1.9 Radiation method

For this method, we will need the Receiver and Transmitter, and at least two operators. Please make sure the target zone and the possible directions pipe crossing, set the working mode of the Transmitter to Radiation, and select same frequency for the Receiver and Transmitter. One operator controls the Transmitter and one operator controls the Receiver, keep the direction of the Transmitter and the Receiver perpendicular to the cable/pipe. The two operators should keep distance for 20 meters, and move simultaneously at the direction perpendicular to the cable/pipe. When the Transmitter passes the cable/pipe, the signal will be inducted into the pipe and the Receiver will receive signal. Observe the receiver responding and mark on the ground when peak responding above the pipe. Refer Fig. 4.1.8

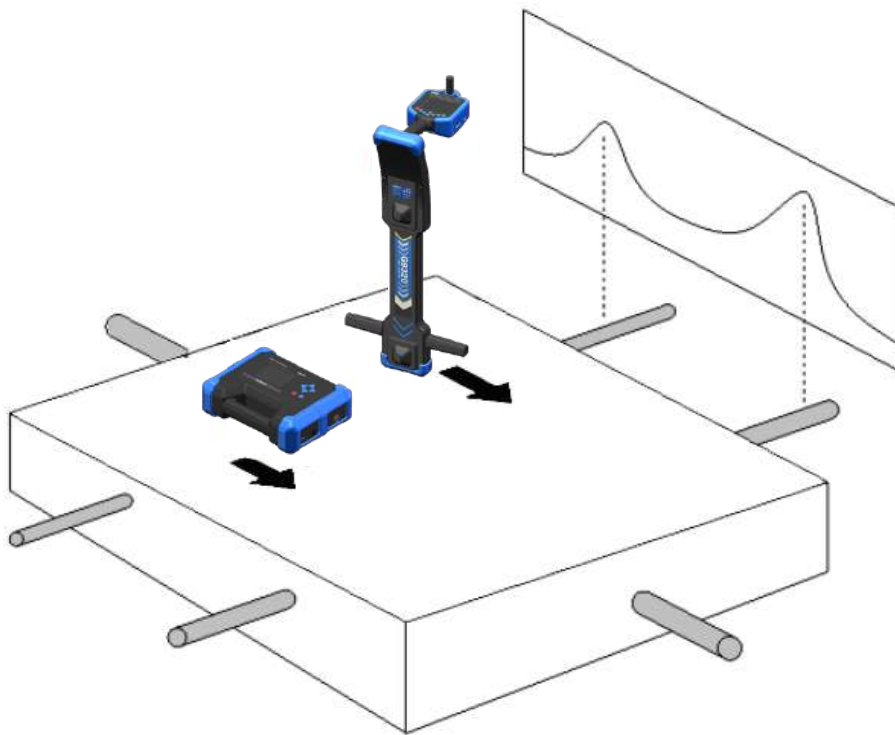

Fig.4.1.8 Radiation zone detection.

After detecting the area in one direction, the operators need to exchange the position of the Transmitter and Receiver, and search the area again in opposite direction. If possible, the operators need to detect the area at all possible directions. Mark all the positions of the cable/pipe, put the Transmitter above the pipe, use the Receiver to trace each cable/pipe. Radiation method is the most reliable method for area cable/pipe detection, but limited to the radiation method itself, the cable/pipe must be grounded and the concrete with metals can not use, we can not ensure that all the cables/pipes can be detected.

4.1.10 precise positioning.

Compass method will have deviation if interference or nearby pipe effect. If need o do the following to increase the location accuracy, we suggest to use below manual measurement method to verification.

Find the target pipeline general position, use PEAK or Valley method and adjust he gain:

- Keep the Receiver perpendicular to the suspected cable/pipe, find the position where there is strongest response.
- Don't move Receiver and rotate it, to find the angle that has the strongest response.
- Keep the angle, move the Receiver left-right, find the point has the strongest response, mark it.

Repeat the above steps if possible to improve accuracy. Refer below Fig. 4.1.9

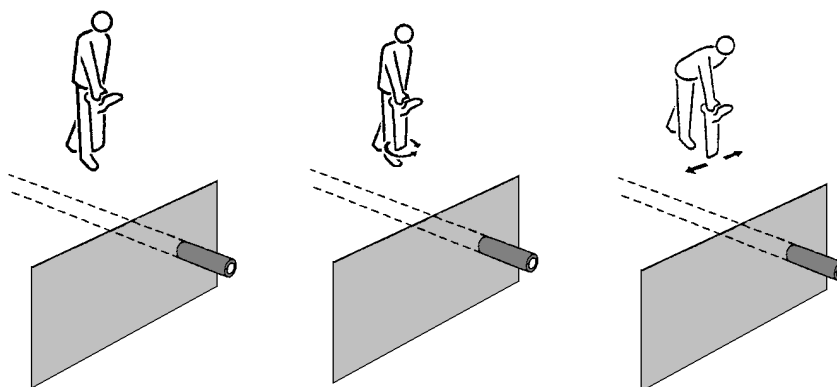

Fig.4-1-9 Precise positioning

Use the Valley method to find the point where has weakest points, and mark them.

If the positions we get using Peak or valley method are the same, then the positioning is accurate. If not, it shows that there is nearby cable/pipe interference, we need to do the correction.

In Fig. 4.1.10, the Valley position and Peak position is at one side of the cable/pipe, while the actual position is at the other side, it is at L/2 position to the Peak position.

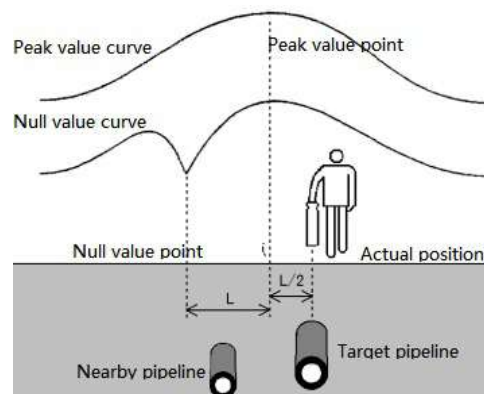



Fig.4.1.10 Position verification

4.1.11 Peak- valley scanning mode for precise positioning.

The peak-Valley Scan mode scans the peak and valley responses of the pipeline for fast, accurate positioning. Short press the mode key  to switch to the peak-valley scanning mode. On the top of the pipeline, the receiver will repeatedly cross cut the pipeline left and right, and observe the amplitude response curve. If the peak and valley values coincide, it indicates that the positioning is accurate; if they do not coincide, it indicates that there may be adjacent pipelines and the positioning is inaccurate, which needs to be corrected.

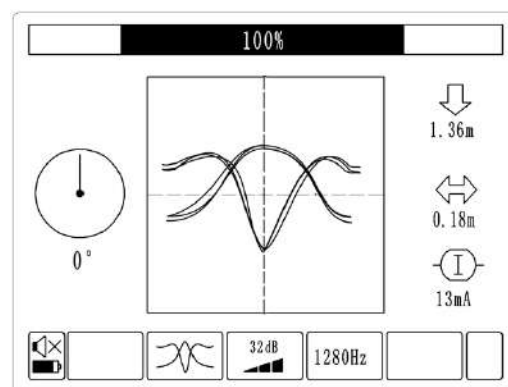





Fig.4.1.11 Precise positioning example

Operation instruction:

1. Signal amplitude is the signal response of Peak mode
2. On the left is the signal percentage ruler.
3. The upper left is the color indication of the peak value method and valley value method.
4. If the curve is too large and distortion, the gain should be reduced; if too small a curve, should increase the gain.
5. Short time press the storage key  to pause the curve recording, and the pause sign will be displayed in the upper right corner. Short time press the storage key  again to continue recording. Long time press the storage key  to clear the curve and start again.

4.2 DEPTH MEASUREMENT

4.2.1 Real-time depth measurement.

When it is judged that the receiver is basically above the pipeline, do the real-time depth and current measurement and the test result is displayed on the right side of the screen, as shown in the figure below:

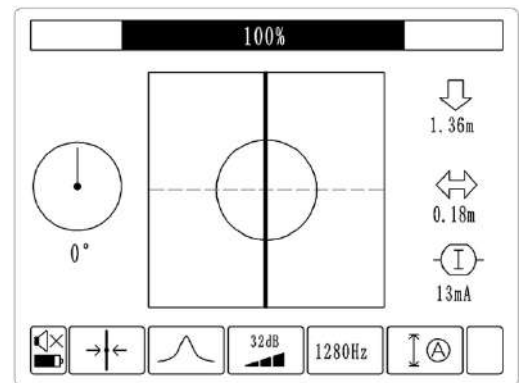





Fig.4.2.1 Real-time depth measurement and current measurement

- The depth measurement is most accurate when the compass shows that the pipeline is vertical and in the center of the compass, and the receiver is directly above the pipeline. The greater the horizontal deviation (the line is to the left or right of the compass), the greater the depth and the smaller the current. When the horizontal offset and tilt Angle are greater than the instrument set value, the depth and current display will disappear.
- The direction of the phase pointer is not a prerequisite for real-time depth measurement, but at 640Hz and 1280Hz, pointing the phase pointer upwards indicates correct tracking and is an important reference as it indicates that it is currently above the target line (rather than the adjacent line). When use other frequencies, there is no phase pointer.
- If the signal amplitude displays the distortion words in addition to the percentage, such as "135% distortion!", indicating that the transmitted signal is too strong and the receiver is saturated with distortion. At this time, the depth measurement error will increase with the increase of the distortion degree. It is necessary to operate the transmitter and press the  key to reduce the output level until the distortion is no longer indicated.

4.2.1 Average measurement

If the depth display is unstable due to various reasons, user can press the measurement key  to carry out continuous average measurement to get gradually stable and accurate measurement results.

After pressing the measurement key , the corresponding position of the key will turn orange, and the average number of times will be displayed. For example, "48Avg" means that the average number of times has been carried out. Maximum average 600 times (1 minute), the timeout automatically exit.

User can also short press the measurement key  at any time to exit the average.

Below the real-time depth and current, the values with Angle brackets are the average measurement results, as shown in the figure right.

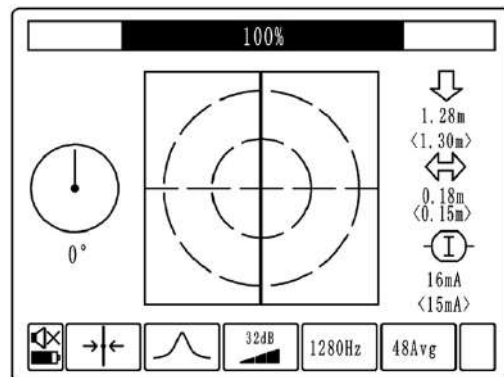

Fig.4.2.2 One-key dept measurement ad current measurement

If the pipeline is located in the center of the compass, but the two lines still do not coincide, it means that the signal is distorted for various reasons, and the depth measurement is not accurate at this time (generally because the measurement is too large and the current is too small).

When the pipeline is located in the center of the compass and the two lines coincide, the signal has no distortion and the depth measurement is accurate!

The higher the coincidence degree of two lines, the more reliable the sounding result is.

4.2.4 Enhance measurement reliability by peak-valley coincidence

Referring to the description of "precise positioning" in the previous section, if the peak and valley are judged to be coincident, the depth measurement directly above it is credible, otherwise it is not accurate (generally, the measurement is too large and the current is too small). It is suggested to use the historical curve pattern to quickly determine whether the peak and valley position coincidence or not.

The following figure is an example, the peaks and valleys in Figure A coincide, the depth measurement is reliable. If screen display similar as in the peaks and valleys in Figure B not coincide, then the depth measurement is not accurate.

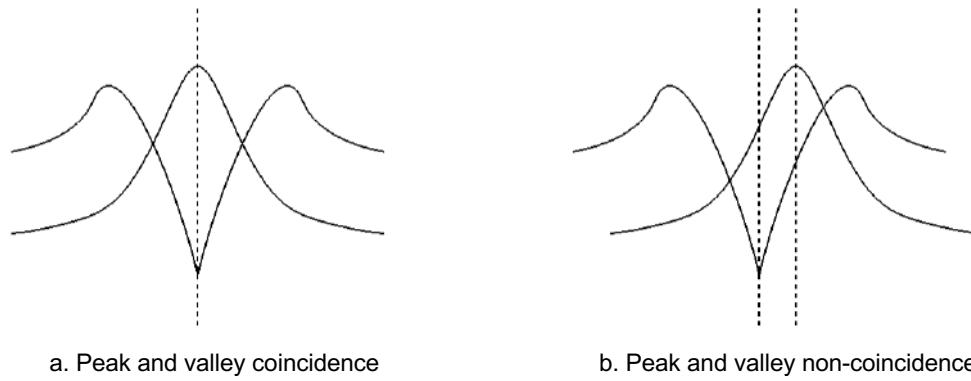

Fig.4.2.4 signal distortion example

4.2.5 Compass targeted depth measurement method

A.Depth: Use the compass to find the pipeline and shift it to the left until the pipeline shown on the compass is left tangent to the green ring with the smaller target. Make a mark on the ground.

Move it to the right until the pipeline until the green ring of the target are tangent to the right and mark it on the ground. The distance between the two marks is equal to the depth of the pipeline, as shown in Figure A below.

B.Double depth: use the compass to find the pipeline and move it to the left until the pipeline shown on the compass is left tangent to the larger blue ring of the target. Make a mark on the ground; Move it to the right until the pipeline is right tangent to the blue ring of the target. Also mark the ground, and the distance between the two mark points is equal to twice the depth, as shown in Figure B below. The depth can be measured and twice the depth, respectively, for cross-validation.

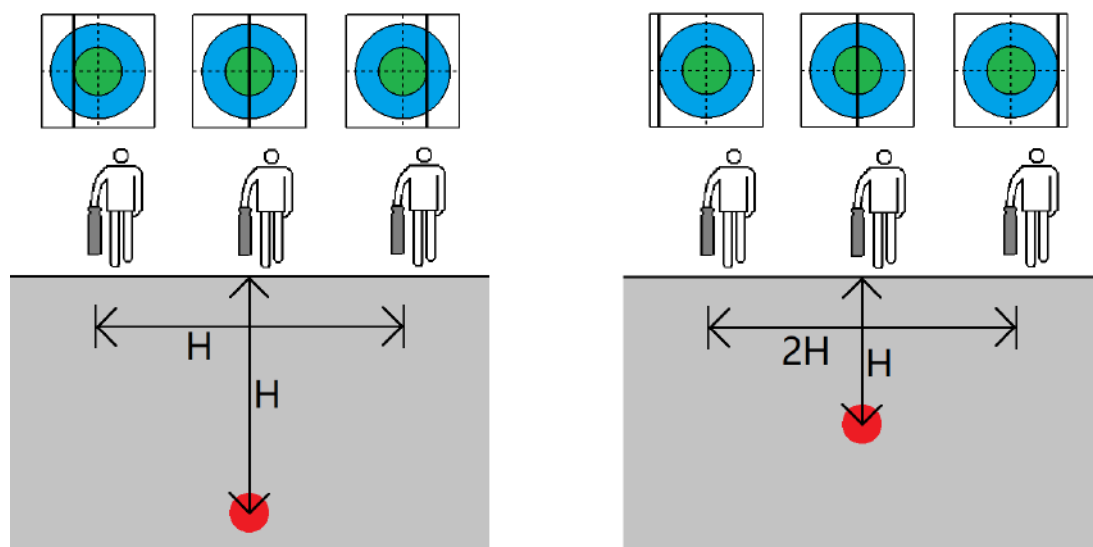

A.Green tangent and distance is depth

B. Blue tangent and distance is double depth

Fig.4.2.5 Compass target depth measurement

4.2.6 Wide peak 80% method depth measurement

Using the wide peak method, find the point with the strongest signal on the pipeline, long press the gain + key, and the amplitude of automatic gain adjustment is 100%;

Then move the receiver horizontally left and right to find two points where the signal amplitude is reduced to 80%, and the distance between the two points is equal to the pipeline depth. The horizontal depth measurement tips below the amplitude bar can help judge whether the amplitude changes reach the preset value, as shown in the figure below:

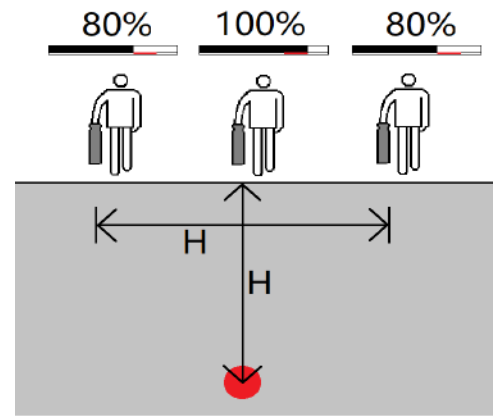

Fig.4.2.6 Wide peak 80% method for depth measurement

4.2.7 Narrow peak 70% method depth measurement

Using the narrow peak method, find the point with the strongest signal on the pipeline, long press the gain + key, and the amplitude of automatic gain adjustment is 100%;

Then move the receiver horizontally left and right to find two points where the signal amplitude is reduced to 70%, and the distance between the two points is equal to the pipeline depth. The horizontal depth measurement tip below the amplitude bar can help judge whether the amplitude changes reach the preset value, as shown in the figure below:

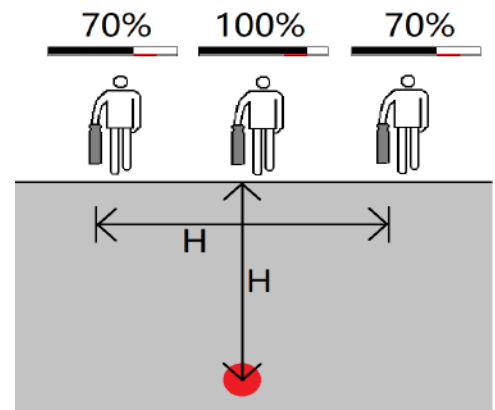

Fig.4.2.7 Narrow 70% method for depth measurement

Advantages: Compared with the wide peak 80% method, the 70% method has stronger anti-interference ability (especially far-field interference).

Disadvantages: The wide-peak 80% method has no theoretical error, while the theoretical error of the 70% method increases with the increase of depth. When it is less than 2m, there is basically no theoretical error, and when it is greater than 2m, the theoretical error begins to increase. When it is 4.75m, the theoretical relative error reaches 5%, and when it is 8m, the theoretical error reaches 10%. Both measured values are larger than the actual values.

Note: As mentioned above, both the wide peak 80% method and the narrow peak 70% method refer to the theoretical relative error under ideal conditions, while the practical test will introduce additional errors due to various reasons.

4.2.8 Valley 45% method depth measurement.

Using the valley method, find the point A on the pipeline where the signal is weakest;

Then tilt the receiver 45° and move it to the side of the pipeline until it finds another point B where the signal is the weakest. Then tilt the receiver 45° in the other direction and move it to the other side of the pipeline to find the point C where the signal is weakest.

In general, Depth is equal to AB, which is also equal to AC. Adjacent pipelines may cause signal valleys not to appear directly above the pipeline, so it would be more accurate to assume that the Depth is equal to half of BC. Note that when tilting the receiver, pay attention to the marker line on the receiver. When one marker line is horizontal to the ground and the other one is perpendicular to the ground, the receiver is correctly tilted 45°.

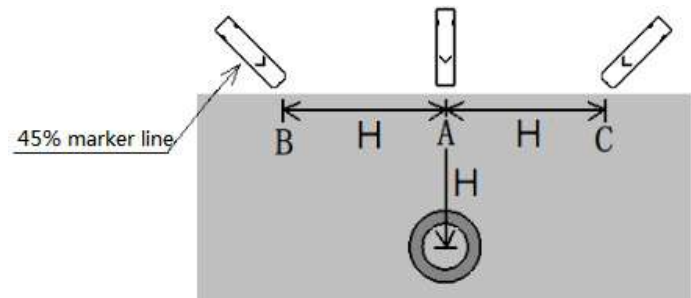

Fig.4.2.8 Valley 45% method for depth measurement

NOTE:



- Loudspeaker output will have slight interference to the real time depth measurement. So if possible, please make it mute.
- Method to verify whether the depth value is reliable: measure the receiver close to the ground once, raise it by 0.5m (or 2ft) and measure it again, if the difference between the two depth data is about 0.5m (2ft), the result is reliable.
- If use Radiation method, the accuracy will be lower than the Direct Connection method or Clamp Coupling method. If must use Radiation method the distance between the Transmitter and Receiver should be at least 20m.
- Try not to measure near the turn or T joint as possible, at least 5m far from it
- The measured depth refers to the distance between the bottom of the receiver and the center of the pipeline, while the depth at the top of the pipeline is less than the depth reading, and the difference is more obvious when the pipeline diameter is larger.
- It can help identify the target pipe by current value. In some cases, the parallel pipeline current is small but the depth is shallow, resulting in the adjacent line signal is larger than the target line signal, easy to cause error tracking. The current of the side-by-side lines is measured separately, and the line with the highest current (rather than the strongest signal) is the target line.
- It can help analyze the condition of the pipeline according to the change of the current value with distance. The transmitter applies a signal to the target pipeline. With the increase of distance, the current intensity will gradually decrease (gradually leaking back to the transmitter), and the attenuation degree is related to the type of pipeline and the soil quality. If the decay rate of the current remains stable without a sudden drop, the line is normal. If the current drop occurs, one case is that the pipeline has a tee (cable T connection) here, and the current is shunt; The other case is that the insulation is broken and grounded here.
- The current measurement is based on the correct depth measurement, if the depth data is not trusted, the current value is not trusted.

Attention!



In some strict pipeline exploration specifications, no matter what equipment is used, the results of automatic sounding are not accepted, so automatic sounding is convenient but can only be used as a reference. To obtain reliable sounding results, multiple methods are needed to cross-validate!

5. PASSIVE DETECTION

Passive (No source) detection does not require a transmitter to inject signal to the pipeline, but only uses a receiver to detect the pipeline using signals radiated by the pipeline itself.

5.1 ROUTE TRACING

5.1.1 Select the frequency

Long press the frequency key  to switch to passive detection frequency, and the corresponding position of the frequency key will turn orange. Short press the frequency key  to switch the receiving frequency band. The following frequency bands are available for selection.

- AFB all frequency passive detection
- Power frequency segment: fundamental (50Hz or 60Hz) and its 2/5/9 harmonics, of which 2 harmonics are used to detect impressed current cathodic protection (CPS) lines.
- Radio frequency band: divided into low, middle and high three frequency bands, respectively, 5~15kHz, 15~25kHz, and 25~40kHz.

The display interface of passive detection is shown in the figure on the right:

The right side shows the real-time sounding and current data of the pipeline, and the amplitude bar shows the current signal strength (only part of the frequency band).

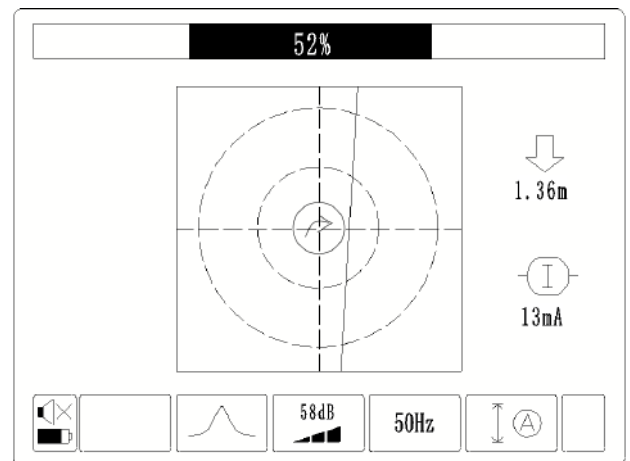

Fig.5.1.1 Passive detection interface

Special: AFB full frequency can search all power frequency and RF frequency bands at the same time, and intelligent selection and primary and secondary distinction, the main signal is displayed using thick lines, and the real-time depth is displayed, and the secondary signal is displayed using thin lines. **Note:** When two thick and thin lines are displayed at the same time, it is generally not considered to be two pipelines.

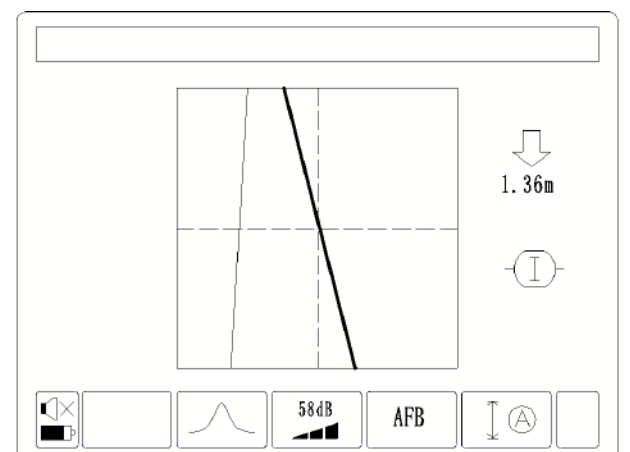



Fig.5.1.2 AFB all frequency detection interface

AFB provides great convenience for passive detection, but the detection sensitivity is not as good as the frequency division detection.

5.1.2 work mode:

Short press the mode key  to switch modes: Switching mode, support wide peak, narrow peak and historical curve mode, but AFB full frequency, because the signal amplitude is not displayed, so switching mode has no effect on it.

- Narrow peak mode:

In passive detection, the signal source is completely uncontrolled and the signal-to-noise ratio is low, especially the far-field interference in the same frequency band may be serious. If the pipeline is mainly detected by the signal amplitude, it is recommended to use the narrow peak mode more, which can suppress the far-field interference to a certain extent.

- History Curve Mode:

If need to be very careful to detect whether there are pipelines underground in the current area without missing anything, it is recommended to conduct a grid-like search in all frequency bands (non-AFB) and historical curve mode respectively in the area to be investigated after rough detection, observe the historical curve, and there will be peak and valley responses above the pipeline, as shown in the figure.

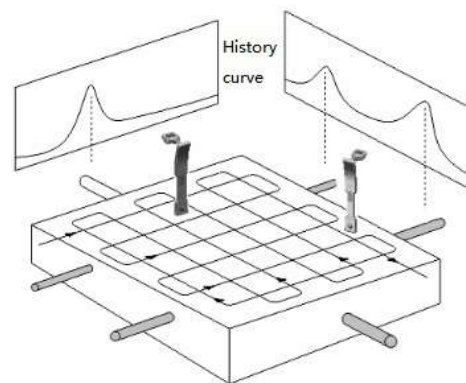

Fig.5.1.3 history curve example

It is recommended to long press the GAIN -- KEY to set the signal amplitude to 40% at the beginning of scanning. In the process of scanning, the gain will be gradually reduced in case of strong signal distortion, so as to avoid missing detection.

The radiation capacity of different pipelines may vary greatly. After finding the pipeline with the strongest signal, the high gain should be adjusted to re-scan. The known strong signal distortion can be ignored, and the pipeline with weak signal can be observed to avoid missing detection.

5.2 DEPTH MEASUREMENT

5.2.1 Real-time measurement:

When the receiver is judged to be basically above the pipeline: that is, the pipeline is basically vertical and in the center of the compass, real-time depth measurement is carried out. The depth value is displayed on the right side of the screen, but the current is not displayed. As shown in Figure 5.1.1, the AFB band pipeline is basically located at the top and shows the depth, while in the two frequencies of 15~25k and >25k of the radio frequency segment, although there is a pipeline display in the compass, it is obviously not directly above and does not show the depth. As shown in Figure 5.1.2: the pipelines corresponding to AFB, 15~25k and >25k are basically located at the top, and all have depth display.

Average measurement: If the depth display is not stable, can press the measurement key  to carry out continuous average measurement to get gradually stable measurement results. The value with Angle brackets below the real-time depth is the average depth.

5.2.2 Compass target depth measurement.

Use the compass to find the pipeline, shift to the left, until the pipeline shown on the compass is left tangent to the green circle of the target, mark it on the ground; Then move to the right until the pipeline and the target green circle are right tangent, and mark the ground. The distance between the two marks is equal to the pipeline depth, as shown in the figure on the right.

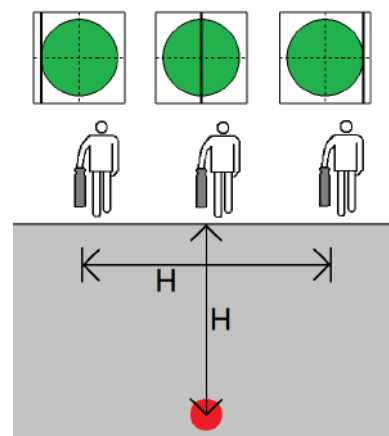

Fig.5.2.1 Compass target depth measurement example

5.2.3 Wide peak 80% method and narrow peak 70% method for depth measurement

In the power or radio frequency bands, the wide peak 80% method or narrow peak 70% method can be used for horizontal sounding, using the same method as active sounding.

Because the passive signal source is unstable and the interference is strong (especially the far field interference), the narrow peak 70% method is preferred.

Attention!

- In passive sounding, no matter which method is used, the result can not be very reliable.
- Wherever possible, use active sounding methods, such as caliper coupled injection signals.
- A variety of methods can be used for cross-validation.

6. CABLE IDENTIFICATION (OPTIONAL)

In the power construction, the cable identification is a work with very strict requirements, because it is related facilities and personal safety. There are three methods: Clamp smart identification, Clamp current measured identification, and sensor Identification.

6.1 CLAMP SMART IDENTIFICATION

Clamp smart identification is the clearest, the most powerful anti-jamming method.

6.1.1 Signal transmitting method

- The frequency of receiver must be settled as 1280 Hz or 640Hz. The fault frequency, 1280 Hz, can meet the most test requirement. If the cable is too long, use 640 Hz.
- For dead cable, should select the direct connection method, and the best connection is core-ground connection; If it is not convenient to connect the cable, suggest also can use phase to sheath connection, don't use sheath-earth connection.
- For running cable, best choice is clamp coupling method, if it can't be used, should use with caution null line/ grounded line/ sheath injected method.
- Can not use the radiation method to transmit signal.

6.1.2 Accessories connection

Insert the plug of the flexible caliper lead into the accessory input socket of the receiver.



Fig.6.1.1 Receiving flexible clamp connection

6.1.3 Receiver interface introduction

Power on and the receiver will automatically identify the connected accessories and set as Clamp receiving mode as below:

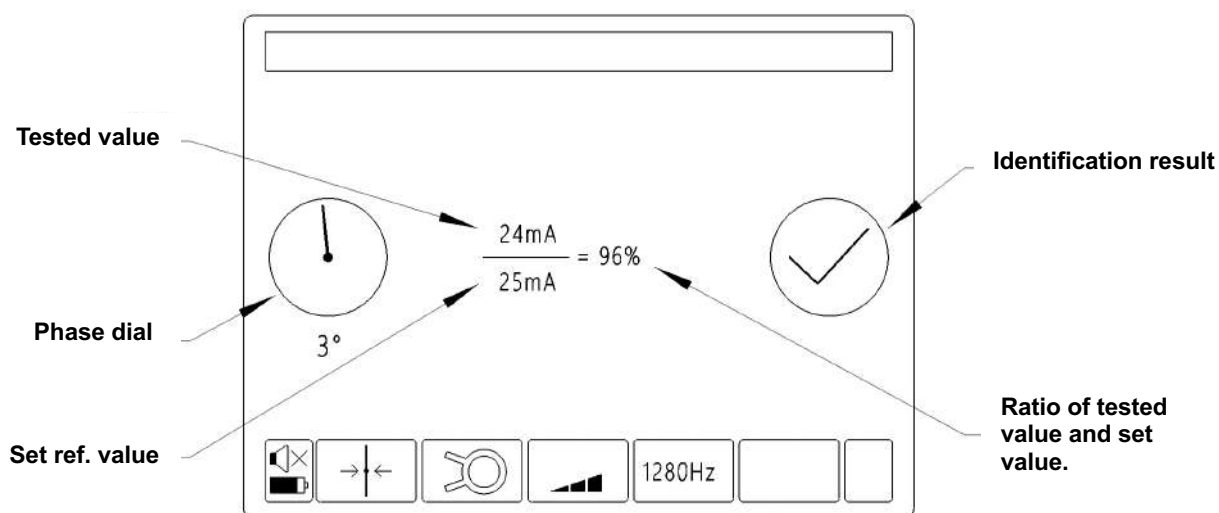



Fig.6.1.2 Clamp identification interface

Receiver default frequency is 1280Hz, we should set it same as transmitter. Under the clamp mode, we don't need to adjust the gain and device will directly display the current value and show it's percentage result with set reference current. Phase dial will display the current phase. The identification result will display Correct  or Error .

6.1.4 Set reference

Use the Set. Reference method, we first need to measure the target cable current intensity and phase in known position as reference. Compare the measured result of some point with this reference result to distinguish. The process of measurement and record the result of current and phase is called Set. reference.

The setting reference should near the transmitter, and not be interfered by it. When using clamp coupling method to transmit signal, it should be leave the transmitting clamp at least 2m. The receiving clamp should lock the target cable.

The direction arrow of clamp should point to cable terminal.

Short press the set reference key \oplus , and the corresponding position above the calibration key will turn orange and display the question mark:?, asking whether to perform phase zero calibration. Pressing other keys will cancel the calibration operation. If short press the set reference key \oplus again, it will display: OK! which indicating that calibration is completed and current phase position return to zero: The phase dial pointer points to the top, the Angle under the dial becomes 0° , as the phase measurement benchmark in the future, and the current value is used as the denominator of the comparison calculation (reverse display), and the identification result is shown as correct \bullet . The following identification and measurement are taken it as the benchmark.

When power off, the data will not be lost after calibration is completed.

When another cable is identified, it must be re-calibrated.

6.1.5 Identification

Leaving the reference point, arrive at the identified point, then using the clamp to lock the cable.

Pay attention that the direction arrow of clamp should point to the cable terminal.

If the locked cable is the target one, the current intensity and phase of measured point will be similar with the reference point. If it meets the following standards, it will be the target cable:

- The current value is greater than 75% of reference value, and less than 120%.
- The phase difference of current doesn't exceed 45° .

Then the identification result will be correct \bullet . If it doesn't meet above standards, it is the neighboring cable, the identification result will error \otimes .

Refer below fig.

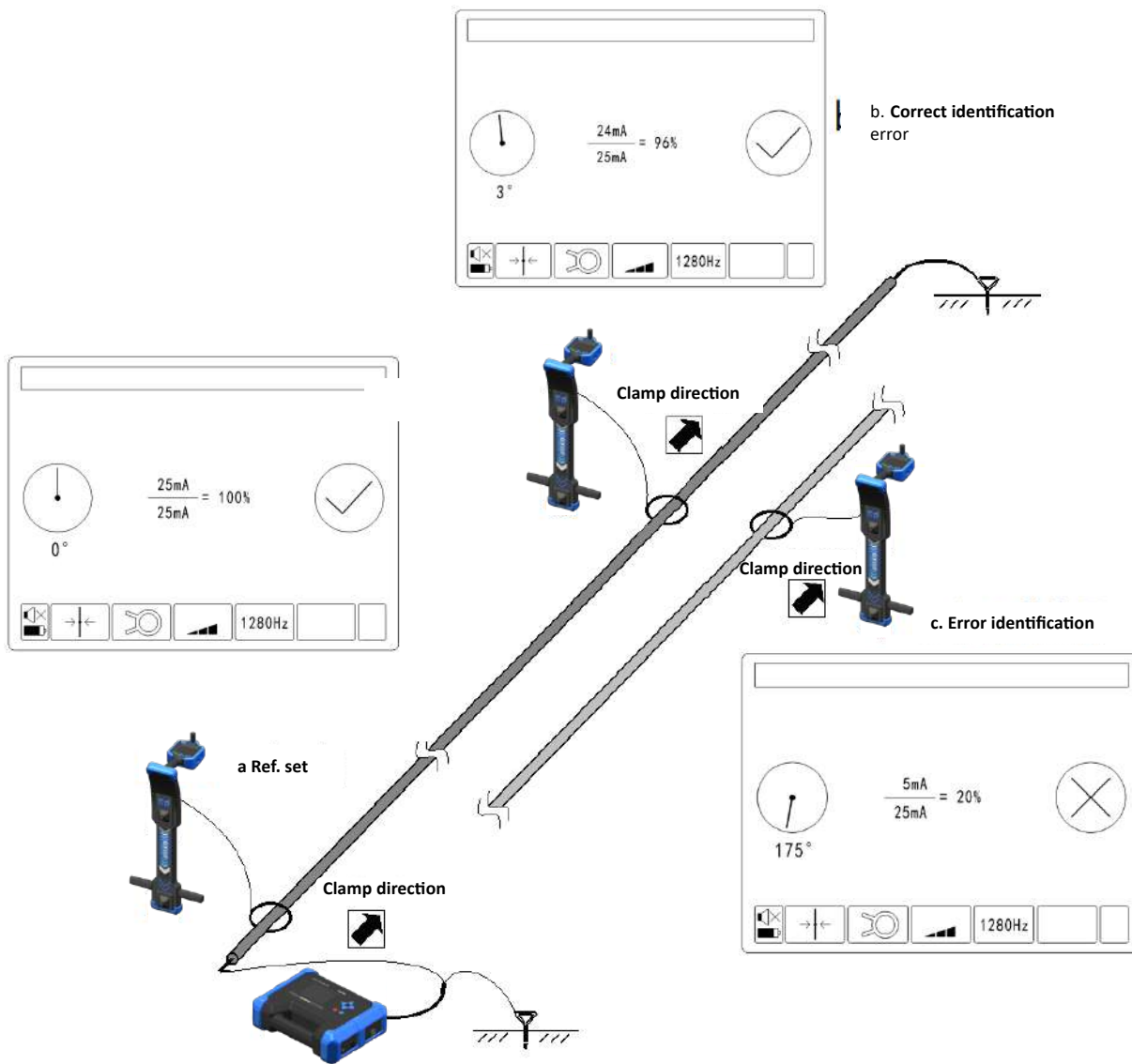

Fig.6-1-3 Intelligent clamp identification process



- When setting reference and identifying, the direction arrow of receiving clamp must point to cable terminal and be closed well.
- The connection of core wire-earth is very complex, but the effective current in the target cable is the most, and less susceptible to interference by neighboring cable. Priority should be used. Example: current of target cable is I , phase is at 0° vicinity, identification is correct; current of neighboring cable is much less than I , phase is near 180° or unstable, identification is error.
- When transmitting the signal with phase to sheath connection, if no parallel cable, the effective current of target cable will be smaller; if have, the effective current of target cable will be the sum of other cables.
- - Example A: the path of 3 cables is same (including the target cable), the test result is: the current of target cable is I , phase is at 0° vicinity, identification is correct; the current of two neighboring cable is $I/2$, the phase is at 180° vicinity, identification is error (as shown in Fig 3.1.4)
- - Example B: the path of 2 cables is same (including the target cable), the test result is: the current of target cable is I , phase is at 0° vicinity, identification is correct; the current of

neighboring cable is I, the phase is at 180° vicinity, identification is error. Because the current is same, the identification is only by the phase, and also should pay attention the clamp direction

- - Example C: the cable is parallel with the target cable, but the path is not same (generally, the terminals are in different position), the test result is: the current of target cable is I, but the value is smaller than injected, phase is at 0° vicinity, identification is correct, the current of neighboring cable is near to 0, phase is near to 180° or unstable, identification is error (as shown in Fig 3.1.3 phase-sheath connection).
- If transmitting the signal with sheath to earth connection, if the insulating sheath was damaged, the current after the damaged point will be reduced. It will effect judgment with current intensity criterion. So, not recommended.
- If transmitting the signal to running cable with clamp method, the transmitting clamp will radiate signal to space, and it will interfere receiving. So, when setting reference, the distance between transmitting clamp and receiving clamp must be 2~5m. Method to judge whether interfered : setting reference first, then unlock the cable and close the clamp in air at the same position. Observing the measured current value, if the value is much less than the reference and near to 0, that means the distance is enough; otherwise, should continue to increase the distance.
- If transmitting the signal to running cable with clamp method, the both ends of cable must be grounded well to form a larger coupling current. If the active current is small, check whether clamped the target.
- In order to improve the reliability of identification, sufficient current should be injected, and identification and judgment can only be carried out above 1 mA, otherwise it will be judged as identification error.

Safety Warning!

- As the cable identification involves facilities and personal safety, it is necessary to distinguish as following. First, according to various on-site information (such as cable diameter) to exclude the good cable based the test result. The remaining should be analyzed enough according to the current intensity and phase of parallel cables, and then judged.
- The right judgment is based on the right operating. Must verify correct connection and setting.
- If two or more cables show identification right or wrong, and the difference of current value and phase is little, must pay more attention, don't jumping to conclusions. The problem maybe the connection of transmitter, so should first check the following error:
 - Forgot to set reference or set wrong.- The clamp direction reverse.
 - In identifying, not lock target cable, and only lock neighboring cable.
 - The transmitting method is wrong.
- If not determine yet, please using other method.

6.2 CURRENT MEASUREMENT BY CLAMP

Except the 640Hz and 1280Hz, other frequencies only support current measurement but can't measure the phase or set reference. So can't use the intelligent identification. But we still can use the current value to distinguish.

Refer below fig.

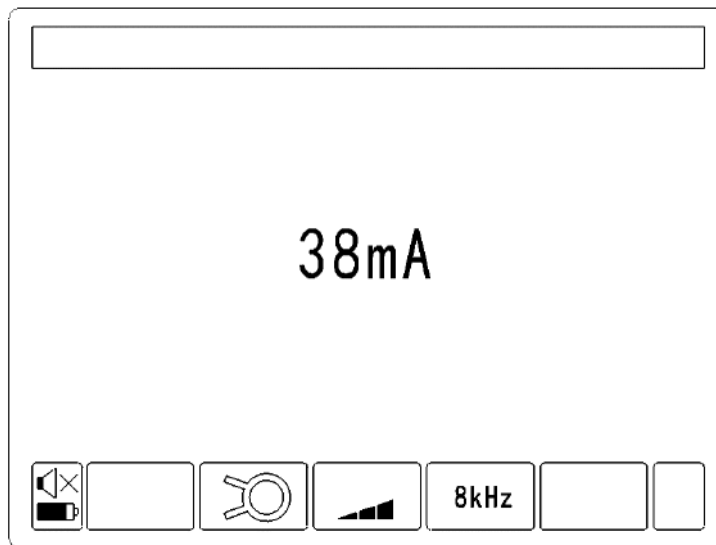

Fig.6.2.1 Flexible clamp current measurement

For 8 kHz,33kHz,82kHz and 197kHz, because the frequency is very high, the signal leakage through the distributed capacitance is very big, so the measured current value will gradually reduced following with the increasing of distance.

The signal injecting method of clamp current measurement and attention matters are similar as intelligent clamp method. Preferentially adopt the intelligent identification and the current measurement method is only a auxiliary method.

6.3 SENSOR IDENTIFICATION

When the field condition is that there are many cables and they are too close, and we cannot use the clamp to clip the cables, we can use the sensor method.

6.3.1 Accessories connection

Sensor accessories assembling method: contact the receiver accessories connection cable (blue mark) with sensor and receiver accessories input socket. Refer Fig. 6.3.1



Fig.6.3.1 Sensor connection

6.3.2 Interface introduction:

After sensor connection, when power on, the receiver will automatically recognize the connected accessories and set as Sensor receiving mode. Reference interface as below Fig.6.3.2:

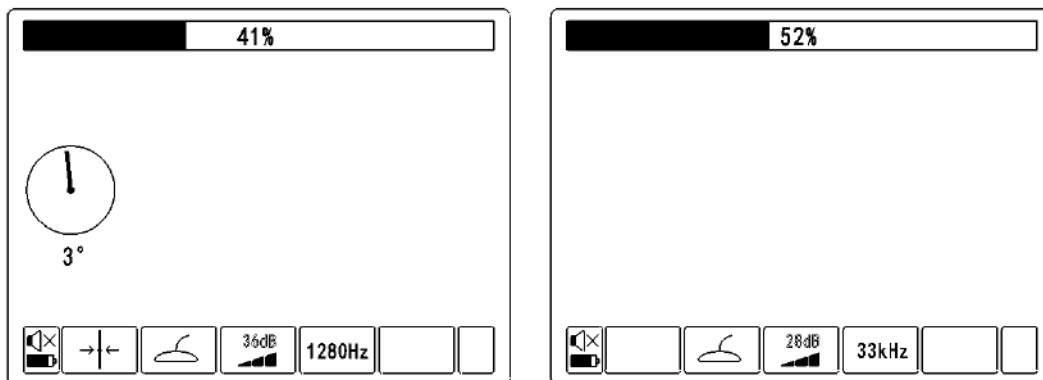

Fig.6.3.2 Sensor identification mode interface

The sensor only has the probe coil external, so other operations are exactly the same as using the internal coil.

By holding the stethoscope close to the cable under test and as far away from the adjacent cable as possible, there will be a large response on the target cable and a small response on the adjacent cable. The target cable is manually distinguished from other cables according to the magnitude difference of the signal amplitude.

The sensor is suitable for all frequencies. When 640Hz and 1280Hz are selected, the current phase can be measured, the anti-error tracking function can be used, and note that the arrow on the sensor points to the end of the cable. Other frequencies have no phase display. As shown in the picture above:

At the near end of the transmitter, the sensor can be placed close to the target cable and adjusted to the appropriate gain. When identifying unknown points, the gain should not be adjusted any more, which can accelerate the identification speed and improve the accuracy.

Refer below Fig.6.3.3

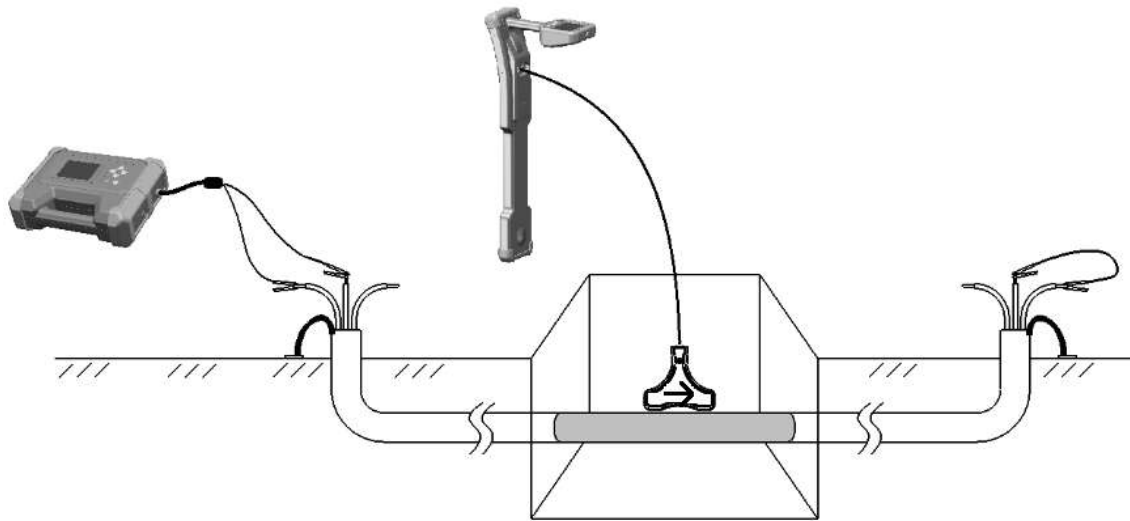

Fig.6-3-3 Sensor identification

7. PINPOINT FOR GROUNDED FAULT OF PIPELINE (OPTIONAL FUNCTION)

The grounded fault of pipeline included: A. Insulation protection layer damage of insulated pipe; B. Grounded fault of non-armor low voltage cable; C. Sheath fault of high voltage cable (especially for UHV single core cable). For these types fault, it usually uses step voltage to pinpoint with A-frame.

7.1 TRANSMITTER FAULT GROUNDING BOOSTER CONNECTION

Plug the fault detection booster (optional) into the output socket of the transmitter; Then the transmitter directly connected to the output cable end of the 5-core red plug into the fault detection booster output socket.

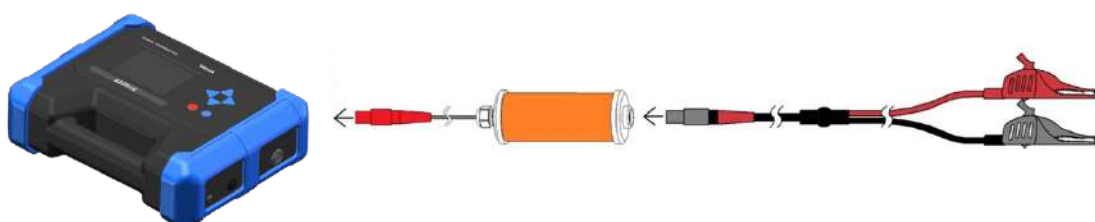

Fig.7-1-1 Transmitter fault locating boost connection

7.2 TRANSMITTER INTERFACE INTRODUCTION

Power on and the transmitter auto identify the connected accessories. Set the fault locating HV 1Hz mode and the interface as below:

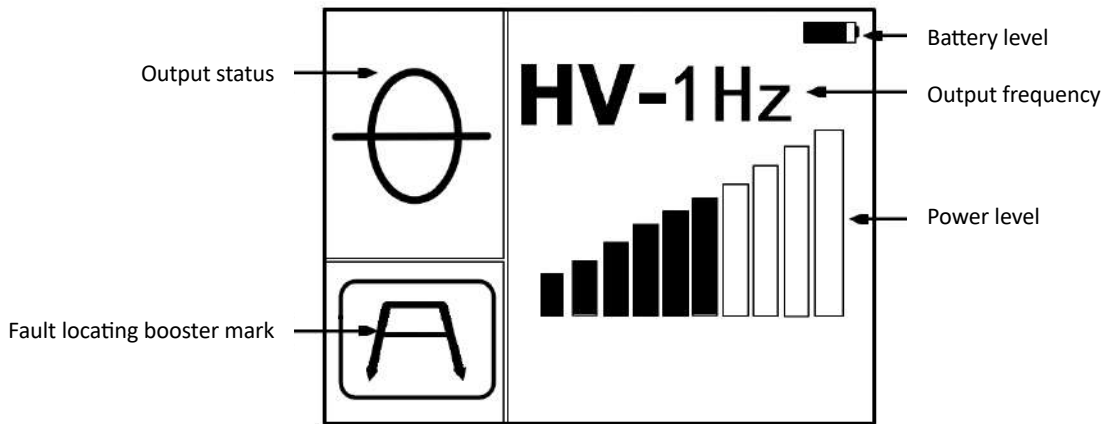

Fig 7.2.1 Transmitter fault locating HV rising output interface

7.3 SIGNAL TRANSMITTING

First, disconnect all the grounded connection of the pipeline, and keep it in reliable floating insulation. The transmitter works in direct connection mode, the black alligator clip of direct connection lead should connect with grounded stick, the red alligator clip should connect with the fault pipeline:

- ① The protective layer of the insulated pipe is damaged: the red crocodile clip is connected with the metal part of the pipeline.
- ② for unarmored low voltage cable grounding fault: red clamp and fault connection.
- (3) for high-voltage cable sheath fault: red clip and cable sheath connection.

As an example of non-armor low voltage cable, the connection is shown in the fig. 7-1-3

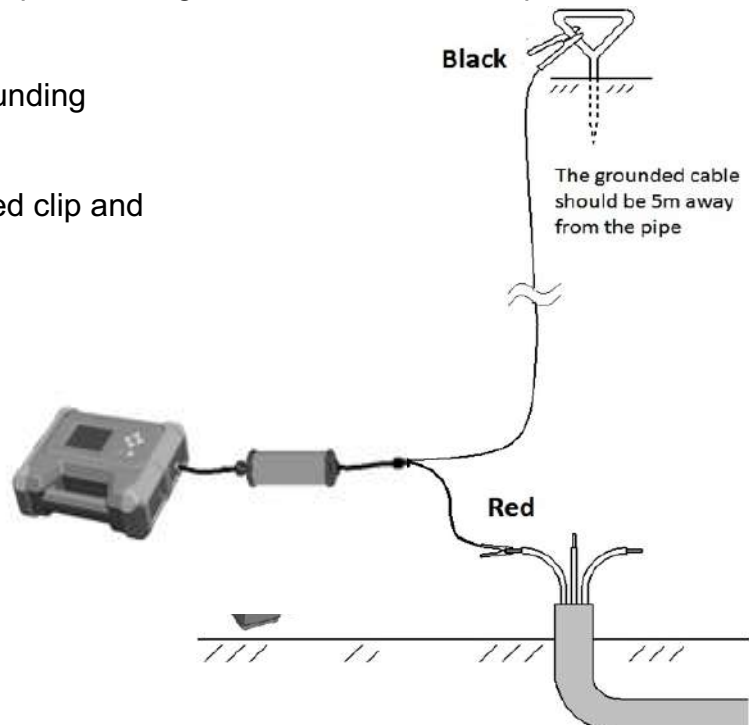

Fig.7.3.1 Grounding fault pinpointing connection

Note:

- Selection of grounding bit location: the grounding bit should be hit 5m away from the pipeline, and the black grounding wire should be perpendicular to the direction of the pipeline as far as possible.
- Do not connect the ground clamp to the water pipe or other pipelines, otherwise it will interfere with the normal pinpointing.
- There should be no other pipelines between the grounding bit and the target pipeline as far as possible. The passive detection method can be used to check before grounding rod is played.
- In the substation signal transmission, it is not convenient to use the grounding rods ground, at this time can use the ground grid as the grounding point, but if the fault occurs within the scope of the ground grid, the instrument may not be able to make a correct reflection and miss the check.
- Fault location can only use HV 1Hz frequency, and it is best to adjust the output power to the maximum.

ATTENTION: THE FAULT LOCATION HV BOOSTER MAX. OUTPUT 1000V!!!

7.4 ACCESSORIES CONNECTION : A FRAME

Assembling the A frame:

Screw the two probes into the hole on the frame bottom. Contact the receiver accessories connection line (with blue mark) with A frame port and receiver accessories input port. Noticed to lock all the connectors. Refer below Fig. 7-1-4

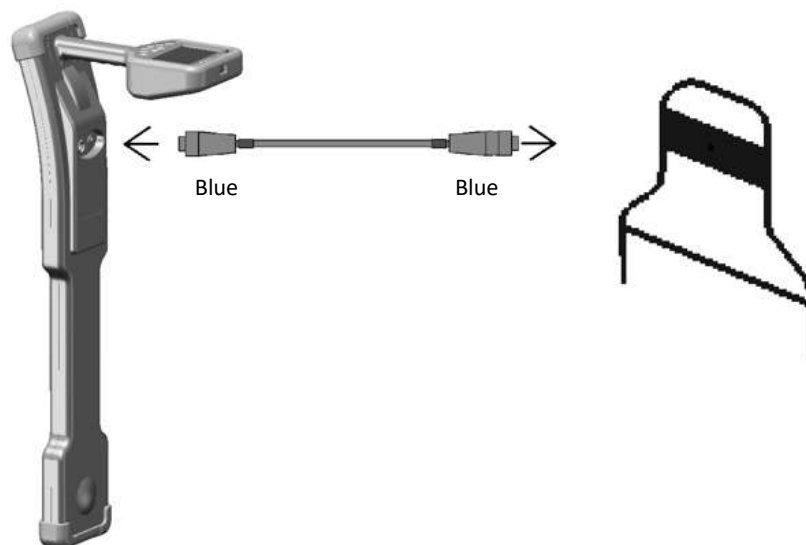

Fig.7.4.1 Receiver A frame connection

7.5 INTERFACE INTRODUCTION

After power on, device will automatically distinguish the connected accessories and set as A frame receiving mode, interface as below Fig. 7.5.1

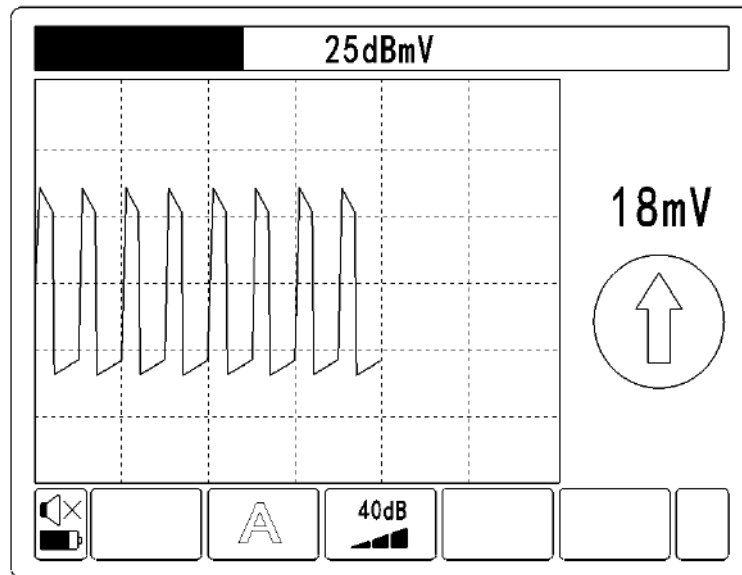





Fig.7.5.1 A frame fault location interface

7.6 CONFIRMATORY TESTS AT NEAR-END

Before detection, it is suggested first do the confirmatory test near the stick, and to determine whether this method can be used to detect the fault.

The signal is injected to pipeline from transmitter, and leak out to the ground at the fault point. The leakage current will gather to the rod, then return to the transmitter. If the receiver can get the strong enough signal near the rod, and it has right direction response, that is to say the injected signal is strong enough, it can content the requirement of detection; Near the rod the signal will be strongest, if there is no right response, that is to say maybe the fault impedance is too high, the current injected is too small, so the fault can't be detected.

Tests at near-end : The probe of A-frame should be drilled into the ground far away from the grounded rod at a distance of 1m. A-frame red end should point to the end of the pipeline direction. Check the voltage and phase, if both value is stable, it means the receiving is normal. Noticed: The normal signal waveform should be impulse DC square waveform and the fault location direction should be forward .

If the voltage value is very small, the phase is also not very stable, the fault location display between  and . It means the injected signal is too small to receiver. Possible reasons: Error wiring, or fault resistance it too high to form valid testing current.

Circle Confirmatory Test: If receiving well, according to black near and red far principle, (black near end, red far end) , around the grounded rod for one circle, there will be stable response and the arrow always should point to forward 📍.

Determine the response range: From the near-end of pipeline, start the confirmatory test gradually, the red end of A-frame should point to the pipe terminal. Along with the distance increasing, the signal is reducing gradually, phase will be unstable, and the locating direction may points to back sometimes. When the signal can also just be distinguished correctly, record the location, the distance between this position to earth rod will be the max. one-way responding range.

Considers pipeline's buried environmental factor (Such as extra high voltage cables installed in cable trench, only can do confirmatory test outside the trench), the fault point response range is smaller than the grounded stick response range generally. So, we suggest that the 1/3—1/2 of the response range should be as the confirmatory test spacing. For example, the measured response range is 20m, the suggested confirmatory test spacing will be 6—10m. When we take this value as spacing to detect, we can avoid missing the fault point, and also can accelerate the test speed. If using the grounded grid of power substation as the ground of transmitter, the confirmatory test can't be done. The suggested confirmatory test spacing is 3—5m, it can meet most need. If the fault impedance is higher, the spacing should be reduced.

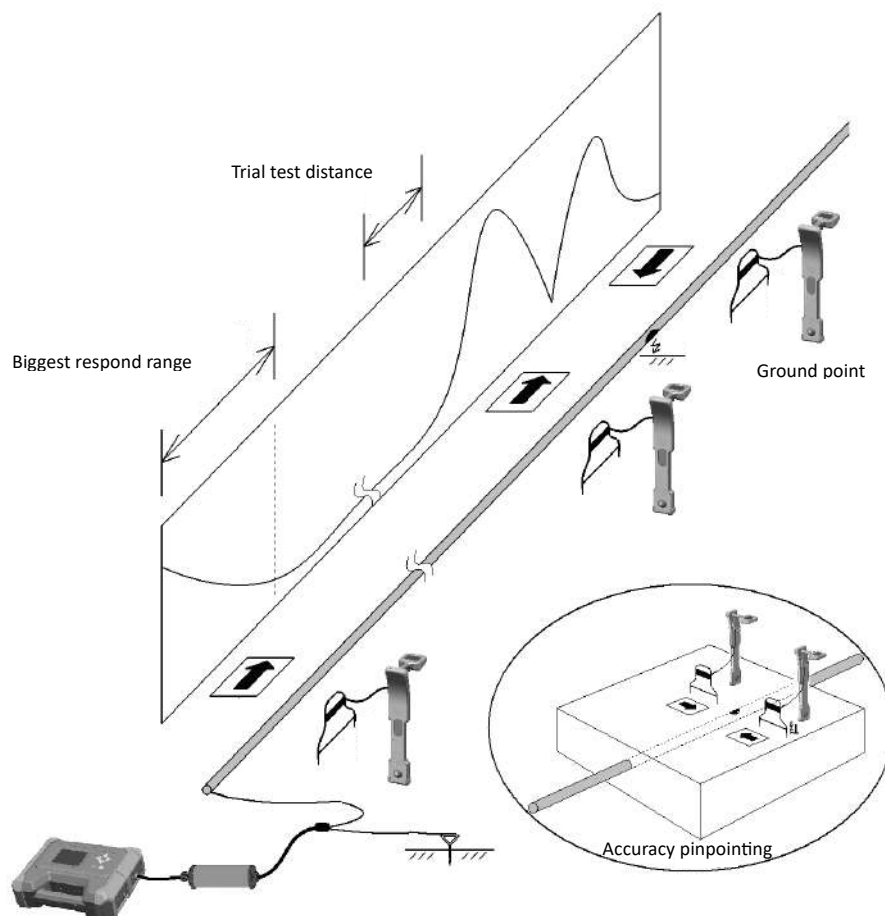

7.7 FAULT LOCATING CONFIRMATORY TESTS

From the near-end of pipeline, facing the terminal, red end of A-frame pointing to the terminal, we start the confirmatory test with the same spacing and gain every time. At beginning, because near the earth stick, the signal is strong and stable, the arrow points to forward. With the distance increasing, the voltage is reducing gradually. Going on forward to test, until find the stable point, that is to say we are closing the fault point. Observing the arrow: the arrow pointing to forward means fault point in front; the arrow pointing to backward means fault point in behind. According the arrow direction, we gradually approximate to the fault point, and during this process to reduce test distance gradually. Finally, when the fault point is right located between the two probes of A-frame, the voltage intensity will have a sudden drop, and a little movement will have acute changes. Moving the A-frame at a small spacing, will find a point. It is the lowest intensity point with direction suddenly dropping. This is the fault point. The A frame fault location process refer above FIG.

If the pipe path is not very clearly, please make the A frame direction to vertical with the pipe and do the testing. Until find the points which reverse direction against the arrow and close to the fault point and find the accuracy position.



- When locating, the operator need to face to the pipe terminal and make the A frame red side in the front (points to the pipe terminal), and the receiver direction need to be same (face to the pipe terminal).
- If the cable is laying in cement cable trench, and is covered with cement cover, the best detection position is upon the ground, and not upon the cement cover.
- If the cable was below the surface hardening road (bitumen, cement or brick), would better do the detection in the grass/earth beside the road. If it is too far away from the cable, the detection result will be worse. Then we suggest to reduce the test spacing.
- If directly in dry and surface hardening road detect, the effect is poorer. The wet surface will be better than it.
- This method can't be used to detect phase grounded fault of armor cable. Because the armor is very possible to multi- points grounding, and these points all will be measured as fault points and it's difficult to distinguish real fault position.

ATTENTION! THE FAULT LOCATION HV BOOSTER MAX. OUTPUT 1000V!!!

8. CABLE FAULT PINPOINT FOR LOW IMPEDANCE AND BREAK FAULT

This chapter is an auxiliary one, read it if needed.

When the cable fault impedance is lower, if use the HV impulse current method to locate the fault, the voice of the fault point discharging is weak, especially when the metallic grounded there will be no voice. Acoustic Measurement precision fixed-point failure,so we need to use the audio frequency induction method.

Audio frequency induction method is used in the low impedance fault that the resistance is no more than 10 Ohm. Using the Audio frequency induction method to locate the fault of two phase or three phase short circuit (or combined grounded), we can get a satisfying result, the general location error is 1-2 m.

For the break fault, we also can use Audio frequency induction method.

8.1 PHASE TO PHASE SHORT CIRCUIT FAULT PINPOINTING

8.1.1 Signal transmitting method

As shown in Fig. 8-1-1, first disconnect the connection between the both ends of cable metal sheath and ground. The connection between the null line of low voltage cable and ground also should be disconnected. The transmitter is in the direct connection output mode, and should connect to two fault core wires.

The receiver must be moving parallel to the cable, and use the peak method to detect.

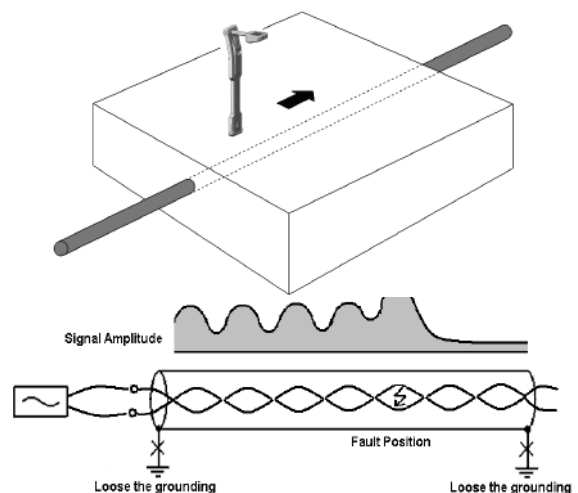

Fig.8.1.1 A frame fault locating process

8.1.2 Pinpointing method

As the cable twist wire along the cable path forward, before the fault point, when we move forward along the path, the signal amplitude will regularly change according to cable torque. When we is in the upward of the fault point, we will get the strongest signal amplitude. If we move forward on, the signal amplitude will reduce to a little and stable value. Better to use the working under the history curve mode and the receiver will show the similar curve as the signal amplitude curve shown in above Fig. 8.1.1

8.1.3 Attention

- For the fault impedance: should be close to 0 with the meg meter measured, no more than 10 Ohm. If over 10 Ohm, should be burned down to low impedance first. If the measurement is 0 with the mega-meter, that doesn't mean the fault is low impedance fault, must measure with the multi-meter.
- All the grounded connection of cable metal sheath should be disconnected, the connection between the null line of low voltage cable and ground also should be disconnected, it is to avoid the interference of other signal.
- Before location, we should find the path first, and marked, otherwise, it is easily to upset the signal rhythm for rising and falling.
- Please note the receiver should be parallel to the cable path, and use the peak method.
- As the connection is between the phases, the effective signal is little, so it is easier to detect using the high frequency signal than the low frequency signal. But the remainder of the high frequency after the fault point is more. We can select the frequency according the fault impedance. If the impedance is very low, we select the little high frequency (like 10 kHz), if the impedance is higher, we select the low frequency.
- From the near end, check for changes in pitch, if on change, that is to say the fault point is in the near end.
- Before the fault point, the pitch will have some changes. Above the fault point, we can get the maximum value. After the fault point, the signal amplitude will reduce to a little and stable value.
- As we have marked the cable path, so we can go forward at normal walking speed . Slow walking is not necessary. For the power cable, the pitch is generally among 1/3m to 1m.
- If the signal breaks or reduces to a little and stable value, that means the fault point is under the last peak of signal. But there also are other reasons: ① Increasing depth; ② There is unmarked branch, the fault point is in the branch, but the operator goes on walking along the main cable; ③ Connector. For all situation, the operator should have no hesitancy to go on walking forward, and remembered the last peak position in head. It is easier to distinguish the connector, the signal is dropping for a little time, and then recovers immediately. If the depth of cable is increasing, you will keep on receiving the signal with pitch changing, so don't worry about it.
- This is the only method that can locate the short-circuit fault point for low voltage, more multi-connection and with a load of cable.
- As the pitch is too small, this method can not be used in telecom cable and control cable. But if we can touch the cable, the method also can be used.

8.2 PHASE TO ARMOR FAULT PINPOINTING

8.2.1 Signal transmitting method

For the low impedance grounded fault of phase to armor, we should use one variation connection of inter-phase. As shown in Figure 8.2.1, first we should disconnect the connection between the both ends of cable metal sheath and ground. The connection between the null line of low voltage cable and ground also should be disconnected, the output of the signal transmitter should connect between one good phase and the armor. At the other end of the cable, the fault phase and the good phase connected with the signal should be short-circuit. Receiver should parallel move long the cable.

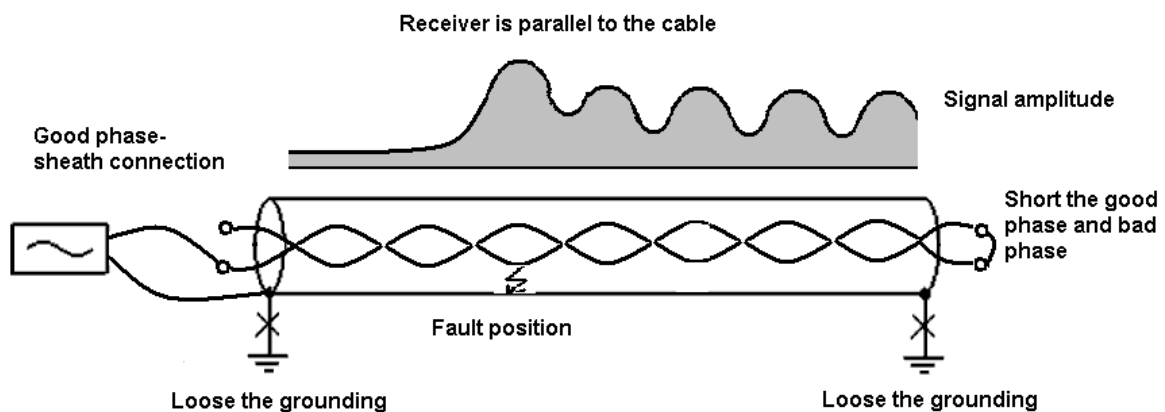

Fig.8.2.1 Phase to armor grounded fault pinpointing

8.2.2 Pinpointing method

This method is similar as the pinpointing method of Phase to phase, but need to notice: before the fault point, the signal amplitude is stable but small. After the fault points, the pitch has some change and the fault point above the first peak value.

8.3 BREAK FAULT PINPOINTING

8.3.1 Signal transmitting method

For the break fault, the transmitter direction connection output is between the faulty phase and ground, don't need to deal with the opposite end. The signal travels from the transmitter to the fault phase cable, it will stop at the break fault point. For the pure break fault, before the fault point, the current flows to the ground through the distributed capacitance between the fault phase and ground, then returns to the transmitter. For the most low voltage cable without armor, if it has the break fault, it generally also will have the grounded fault. The current is flowing to the ground through the fault point mainly, and then it will return to the transmitter. Refer below Fig. 8.3.1

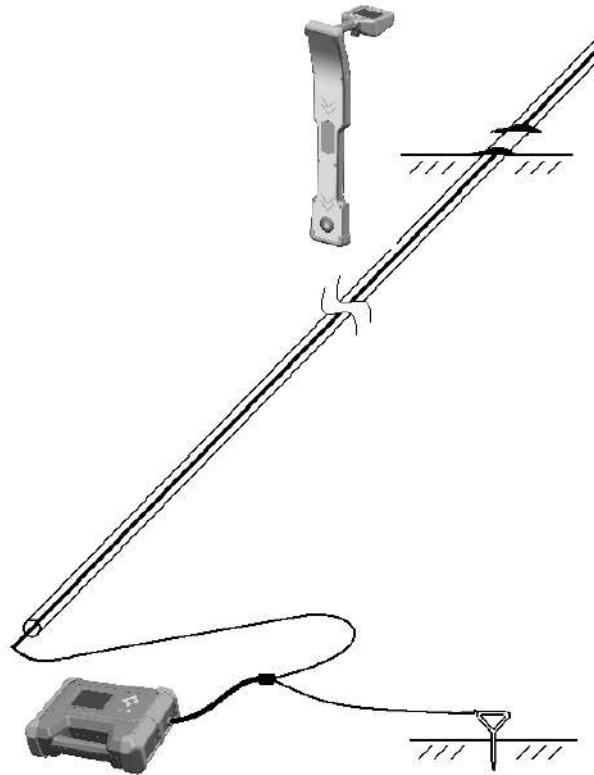

Fig.8-1-3 break fault testing wiring

8.3.2 Pinpointing method

The pinpoint of break fault is the same with ordinary pipeline tracking. Keep the receiver being perpendicular to the cable, using the peak method, starting from the transmitter near-end, gradually move to the remote and detect. Before the fault point, the signal is strong, after the fault point, the signal decreased rapidly. The point that the signal started decreasing is the fault point.

There is no pitch change. As shown in Fig.8.3.2

NOTE:

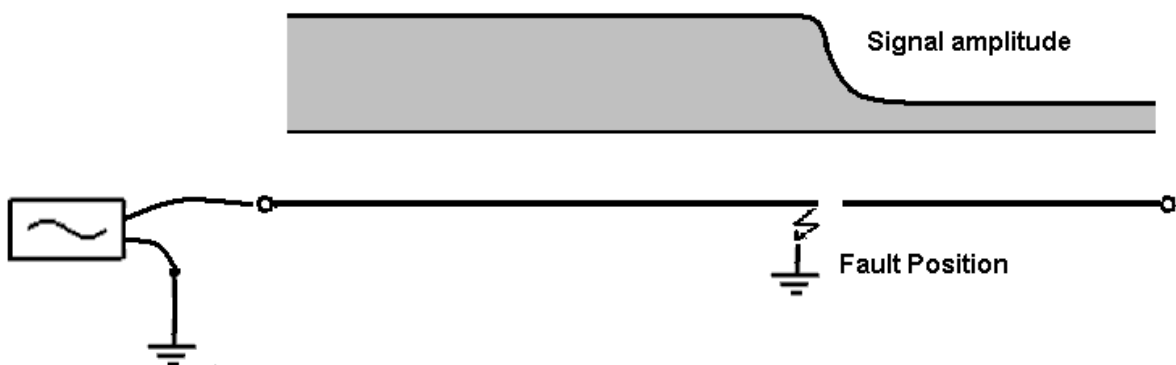

Fig.8-3-2 Break fault pinpointing

- This method is particularly suitable for fault pinpoint of low voltage non-armor cable. For the armor cable, the current will couple to the armor through the distributed capacitor. So the signal will in all the length of cable, and can't distinguish where the fault happens.
- For the break merging grounded fault, we suggest using the lower frequency (like 1280 Hz). For the pure break fault, should use the higher frequency (like 10 kHz). The current value of transmitter can help to select the frequency. When it is low frequency and the current value is large, then should use the low frequency; if the current value is small, should use the high frequency.
- For the pure break fault, with the increase in distance, the signal will continue to decrease. At the fault point, the signal disappears. For the break merging grounded fault, if the grounded impedance not a great, then the signal weakens the phenomenon not to be obvious.

8.4 NO ARMOURS PHASE-EARTH BREAK FAULT PINPOINTING

8.4.1 Signal transmitting method

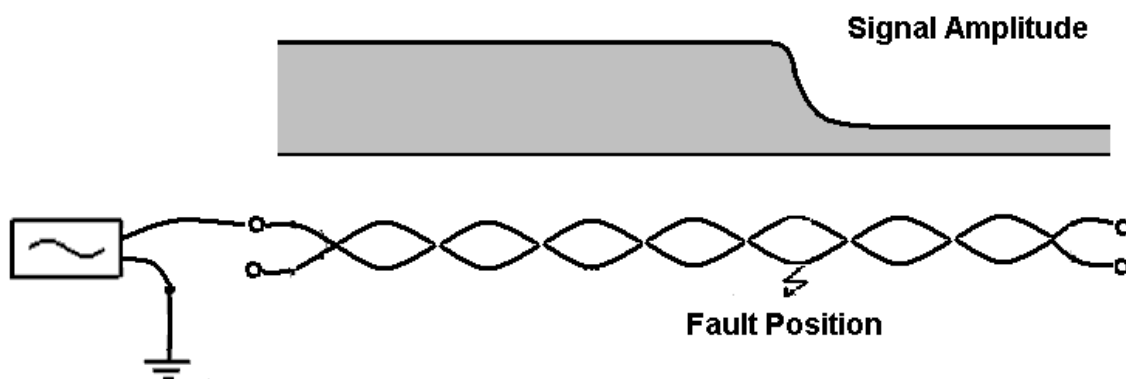

Fig.8.4.1 No armor cable phase to ground fault wiring

As above Fig. 8.4.1 shows, disconnect all the grounded in both ends of low voltage cable's null line and ground line, the transmitter is selected the direct connection mode and connected between the fault phase and ground. The signal flows from the transmitter to the fault phase, at the fault point it will flow to the ground and then return to the transmitter.

8.4.2 Pinpointing method

It is similar with the break fault. Keep the receiver being perpendicular to the cable, using the peak method, starting from the transmitter near end, gradually move to the remote and detect. Before the fault point, the signal is strong, after the fault point, the signal decreased rapidly. The point that the signal started decreasing is the fault point. There is no pitch change.

NOTE:

- Whether the induction method can be used to pinpoint the grounded fault, it mainly depends on the value of fault impedance. The greater the fault resistance, signal changes before and after the fault more weak, that they can not distinguish.
- The lower the frequency, intensity changes before and after the point of fault more obvious. It proposes to adopt low-frequency detection (like 640Hz or 1280 Hz).
- For the fault of phase to ground, the step voltage method is the dominant method that was introduced in Chapter VIII, and this method as a supplementary. Before using the step voltage method to pinpoint, should first detect the cable path. In the path tracking, observe whether the signal amplitude have obvious change. If have, this is a suspicious points, should mainly pinpoint in this region using the step voltage method; if no, that is to say this method can't be used, should use step voltage method.

9. MAINTENANCE AND WARRANTY

9.1 Charging

After each use, the manufacturer's special charger should be used as soon as possible to charge the battery of the equipment; If not used for a long time, charge the host every six months; Before use, please turn on the battery to check the battery voltage. When the battery energy is less than 30%, charge it before use. Charge must have a special care, fully charged to unplug the charger power in time, continuous charging do not exceed 8 hours; Do not charge in sub-zero temperatures.

The instrument has a built-in lithium battery pack, and the continuous working time is different with the output level, but it can generally meet the needs of 8 hours of work a day.

In use, the battery level icon is displayed at the bottom left of the screen, the level of battery power in the green part of the icon, all green represents full power, all empty and blinking indicates that the battery is under voltage, the power is completely used up, and it will automatically shut down after a few seconds.

When it is necessary to charge, connect the AC plug of the charger to the AC220V/110V mains socket, and connect the double C-port fast charging cable to the USB-C port of the charger and the transmitter/receiver. The charging voltage is 12V. If RTK is selected, it must use an RTK-specific charger.

The indicator light of the charger indicates that it is charging, and the green indicator indicates that the charging is complete. Keeping the indicator light green after a period of time helps to charge more electricity.

In the off state, it takes about 3-4 hours for the transmitter to be fully charged from the undervoltage state. The receiver takes about 1.5-2 hours.

Depending on the use and maintenance conditions, the battery pack can generally carry out 300-500 charge and discharge cycles. As the number of charge and discharge increases, the battery capacity will gradually decrease, and the working time of the instrument will be shortened accordingly. If it is too short to be acceptable, please contact the manufacturer/agent to replace the battery pack.

9.2 Warranty And Maintain

Device main unit and accessories are one year guarantee of free maintain, battery is one year free replacement. Beyond one year, only charge for basic component cost for maintaining.

For device breakdown by incorrect using (in the warranty) or device quality problems over warranty, we are responsible for maintaining and only charge basic component cost.

When auto power-off, unable to power on or immediately shut after power on, it's possible because low battery. Charging first and again.

If other problems, don't to maintain by yourself, contact with us first.

INNOVATION
PERFORMANCE
SAFETY
CONFIDENCE
GAZELLE

GAZELLE

sales@gazelleindustrial.com | www.gazelleindustrial.com